

Implements of Husbandry Study

*Phase II Report to the Secretary of the
Wisconsin Department of Transportation*

July 31, 2013

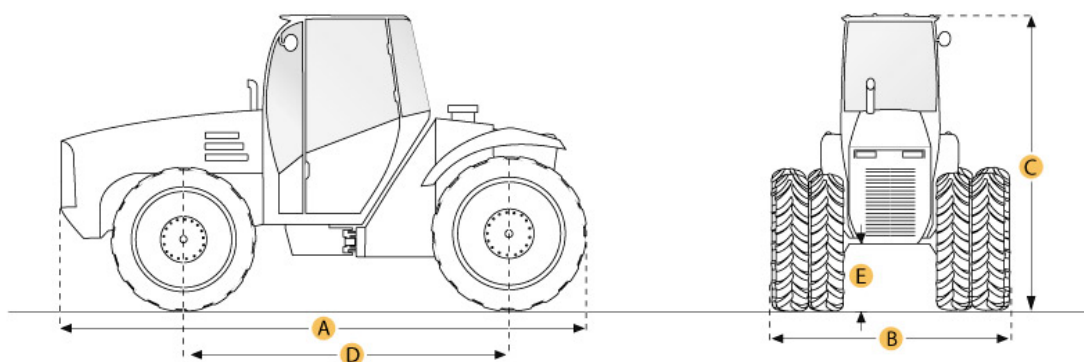

Phase II Report to the Secretary of the Wisconsin Department of Transportation

Implements of Husbandry Study

Prepared by

Wisconsin Department of Transportation

In partnership with

Wisconsin Department of Agriculture, Trade, and Consumer Protection

And with

UW Center for Agricultural Safety and Health
UW-Madison Department of Biological Systems Engineering
UW-Extension Environmental Resource Center
Wisconsin Traffic Operations and Safety Laboratory
Professional Nutrient Applicators Association of Wisconsin
Wisconsin Farm Bureau Federation
Professional Dairy Producers of Wisconsin
Wisconsin Towns Association
Wisconsin County Highway Association
Maxville Truck and Repair
Wisconsin Custom Operators
League of Wisconsin Municipalities
Wisconsin Agri-Business Association
Husky Farm Equipment (Ontario, Canada)
Association of Equipment Manufacturers (Milwaukee, Wisconsin)
Dairy Business Association
Wisconsin Independent Business – Agri-Business Coalition
RCI Engineering LLC

With additional support from

John Deere
Kubota Tractor Corporation
Case New Holland (CNH)
AGCO

Image on cover page is from: <http://www.ritchiespecs.com/> (John Deere 9630T 4WD Tractor).

Contents

Executive Summary.....	4
Initial Recommendations.....	7
Agriculture in Wisconsin.....	9
The IoH Study Group.....	10
Role of Engineering.....	12
Pavement & Bridge Design Factors.....	13
Analyzed Equipment.....	17
Engineering Analysis.....	19
Engineering Analysis Recommendations.....	21
Additional Engineering Research Needs.....	23
Best Practices	
Manure Hauling & Other High Frequency Divisible Loads.....	26
Review of Wisconsin Statutes	
IoH Definition.....	29
IoH CMV Identification.....	30
Education & Outreach Efforts	32
Appendix:	
A. Glossary.....	33
B. Infrastructure Information – Height Considerations.....	34
C. Preliminary Drafting Instructions.....	36
D. IoH Weight Table.....	40
E. Example Written Authorization Form.....	42
F. Engineering Analysis (Equipment Matrix).....	44
G. Equipment Specifications.....	46

Executive Summary

Restoring Balance: Increases in size and weight of agricultural equipment, specifically Implements of Husbandry (IoH), has evolved over time to meet productivity and functionality needs in the field often without consideration of its use on public roadways. This creates a mismatch between the equipment and its suitability for use on public roadways and structures. There is a growing awareness that our public roads and bridges have limits as to what they can physically and safely support. The impact can be seen in accelerated deterioration and a higher risk of failure for pavement, bridges, culverts and to traffic operations.

Today's farm operations and environmental regulations are creating a greater need for agricultural producers to do more than just cross the road. It's not unusual for an IoH to travel miles from farm operation to farm operation, making multiple trips in a day.

The purpose of this study was to explore the options that would restore the balance that supports Wisconsin's vital and diverse agricultural industry, while at the same time preserving the public's investment in state and local roads and bridges and provide for safe travel for all users.

The Wisconsin Department of Transportation (WisDOT), in partnership with the Wisconsin Department of Agriculture, Trade and Consumer Protection (DATCP), solicited the input from a variety of affected parties, including those within the agricultural industry and public road authorities, to form an Implements of Husbandry (IoH) Study Group in fall 2012. A comprehensive list of the study group membership can be found within the IoH Study Group section of this Phase II Report.

The Phase I report issued in January 31, 2013, by the IoH Study Group recommended additional review of:

- Weight
- Written Authorization
- Highway Safety

From the initial kick-off meeting in October 2012 to the present date, education for all involved has been and will continue to be a key in this effort. Early meetings, during Phase I, were spent ensuring the entire study group had a common understanding of the current fleets of equipment, modern agriculture needs and the standards and capacity for roads and bridges. Armed with this knowledge, the study group proceeded to develop recommendations on the use of best practices and changes to current state law needed to strike a new balance between agricultural operations and transportation.

Phase I of this study was issued on January 31, 2013. It was evident to the study group that Wisconsin law has not kept up with today's IoH equipment. The group recommended creating or amending statutory definitions and categories of IoH to assist in determining whether a vehicle, piece of equipment or machinery, or trailer is designed for agricultural purposes and used exclusively in the conduct of agricultural operation. Each category would have simply-defined limits of size, weight and operation to eliminate confusion for farmers, local officials and law enforcement.

For safe road operations, the study group defined an envelope size or maximum size limits for IoH operating on the road without a written authorization. Vehicles, or combinations of vehicles, other than IoH CMVs, will have a maximum size envelope of: 15' (feet) wide - IoH may operate in excess of 15' (feet), but no greater than 17' (feet) without written authorization, but must have additional safety requirements; 13'6" (feet/inches) high; 60' (feet) in length for single IoH; 100' (feet) in length for two IoH; and 70' (feet) in length for three IoH. Equipment larger than these limits may be allowed by written authorization if the roads and bridges are determined to be able to handle the increased size.



Width (15')



Height (13'6")

Width (15' to 17' With Additional Safety Requirements)



Length (60') – Single IoH



Length (100') – Two IoH



Length (70') – Three IoH

Images courtesy of: www.daytonadailynews.com, www.toytractortimes.com, www.aybarn.museum.state.il.us, www.applefarmservice.com, <http://www.youtube.com/watch?v=d5Nb7Wf2cZc>.

Additional recommendations included exploring and documenting best practices for supporting agricultural operations and manure handling. To address other transportation needs and impacts of the agricultural industry, a standing forum is being established.

This Phase II report is designed to report on additional research needs not addressed in the Phase I report. This report addresses IoH weight limits, which is one of the most challenging issues identified by the IoH Study Group. Agricultural equipment is unique and is not easily comparable to commercial motor vehicles (CMVs), such as semi-trucks. IoH's weight impacts are very different, particularly on bridges and culverts. Differences include axle width and spacing, weight distribution, length and tire design. Currently, there are no transportation design standards for IoH. Research in other states is currently underway and this research may potentially lead to the development of more standards, but that work is not yet complete.

While the weight and size of agriculture equipment is a concern for many states, the IoH Study Group is taking the lead on establishing policies on this issue. In addition to the study group's pavement and structure analysis, the study group is very supportive to research studies being done in Iowa and elsewhere. Farm equipment manufacturers are actively participating on our task force and are hoping standards are developed that can be applied universally.

This Phase II report also recommends implementing new safety standards associated with the establishment of a written authorization system to accommodate the unique needs of the agriculture industry and establish best practices for manure management. In addition, a work group of the study group is developing an outreach plan that will include regional meetings and other opportunities to provide and receive input from various stakeholders.

Additional research is needed and the IoH study group plans to continue to work cooperatively with representatives of local municipalities and the agricultural industry. Studying the issues of IoH collaboratively provides a forum to arrive at solutions that both support the state's agricultural industry and protect the transportation infrastructure. In the process, it helps the affected parties understand the impacts and benefits that need to be considered in reaching a balance that best serves the people of Wisconsin.



IoH Phase II Recommendation: A CMV used exclusively for agricultural operations is defined as an “IoH-CMV” and has a maximum total width of 10’ (feet).

Picture courtesy of Dana Cook, PNAAW.



IoH Phase II Recommendation: IoH is given an expanded 15% weight allowance over the limits as established by the Federal Bridge Formula.

Picture courtesy of Cheryl Skjolaas, UW Extension.

Note: *The images of agricultural equipment and implements of husbandry included in this IoH Phase II report is not intended to be bias in any nature toward any manufacturer or their equipment.*

Initial Recommendations

Initial Recommendations: The background on all of these recommendations by the IoH Study Group can be found in greater detail within this Phase II Report. This Phase II Report does not explicitly establish statutory language; rather, the creation or amendments to Wisconsin law are summarized based on suggestions by the IoH Study Group. This Phase II Report will be sent to the Secretary of the Wisconsin Department of Transportation on July 31, 2013. The IoH Study Group, by consensus, offers the following recommendations:

- Clarify the IoH Definition:
 - Create a clearer, simpler definition of IoH to reflect today's agricultural equipment.
 - Commercial motor vehicles (CMVs) used exclusively for agricultural operations are defined as an IoH CMV.
 - All IoH will be exempt from registration.
 - A self-certification will be available for IoH CMVs.
- Create size limits or an "envelope" for IoH:
 - Width envelope:
 - Width of IoH – 15' (feet); However, an IoH greater than 15' (feet), but no greater than 17' (feet) may be operated without written authorization when the IoH operator meets safety requirements to ensure safe passage by other road users.
 - Width of IoH CMV – 10' (feet).
 - Height envelope: Height of IoH – 13'6" (feet/inches); However, an IoH greater than 13'6" (feet/inches) may operate without written authorization. The IoH operator is responsible for ensuring there are no conflicts with over-head obstructions, such as wires or structures.
 - Length envelope: 60' (feet) for a single IoH; 100' (feet) for combinations of two IoH; and 70' (feet) for combinations of three IoH.
- IoH is given an expanded 15% weight allowance over the limits as established by the Federal Bridge Formula, except where posted and during periods of spring thaw. This equates to a maximum single axle weight of 23,000 pounds and a gross vehicle weight of 92,000 pounds. A new IoH weight table will be created to (e.g. 348.30) reflect the 15% allowance based on gross vehicle weight, axle weight and spacing.
- Written authorization to exceed the size envelope and weight limits may be requested on an annual basis from the maintaining authority that has roadway. Written authorizations may only be granted when:
 - The operator is 18 years of age and holds a valid driver's license.
 - IoH meets lighting, marking, and safety requirements pertaining to IoH in s. 347 (safety requirements).
 - A travel or route plan for the IoH is submitted.

Additional conditions may be set by each maintaining authority (local or state) of which the IoH is operating within the context of the written authorization.

- IoH vehicles operating in excess of the 15% allowance will be fined for the amount in excess of standard gross motor vehicle weight or individual axle weight.
- Support exploration of best practices to assist in reducing the wear of roadways and structures. This includes supporting the development of emerging innovations and best practices in manure management.
- Develop a self-certification system for IoH CMVs rather than a plate, sticker, or decal.
- WisDOT, DATCP and study members will conduct an outreach campaign to obtain feedback from stakeholders, including Town Hall meetings (all meetings will take place between 7 p.m. and 8:30 p.m.):
 - August 19 (Dane County UW Extension)
 - August 20 (Country Aire Banquet Hall, Stratford)
 - August 28 (Cashton Community Hall)
 - August 29 (WisDOT Green Bay Office, 1940 Mason Street)
 - September 3 (Chippewa County Courthouse Large Assembly Room)

Agriculture in Wisconsin

Agriculture is the cornerstone of Wisconsin's history, a driver in today's economy and key to Wisconsin's future. For decades Wisconsin has been known as America's Dairyland, but the diversity and impact of Wisconsin's agricultural industry goes much further.

Agriculture contributes \$59.16 billion annually to our state's economy. This is about 12.5% of Wisconsin's total sales. A majority of this economic impact, almost \$50 billion, comes from agricultural processing. Using an industry multiplier, every dollar of agricultural activity yields an additional 52¢ (cents) of industrial sales elsewhere in Wisconsin's economy. Annually, Wisconsin agriculture contributes 353,991 jobs, about 10% of the state's employment. Every job in agriculture supports an additional 0.89 jobs elsewhere in Wisconsin.

None of this would be possible without a sound system of roads and bridges for the equipment used to plant and harvest crops, apply nutrients, deliver milk or transport processed agricultural products to market. The recommendations found within this Phase II report are designed to assist the agricultural industry and protect the investment of the public safety and infrastructure in the state of Wisconsin.



Image courtesy of the Wisconsin Department of Transportation.

The IoH Study Group

Wisconsin Agricultural Initiative: In an effort to clarify statutory distinctions among agricultural equipment types, an IoH task force was created in the Fall of 2012 to examine and analyze current IoH. After the group's submittal of the Phase I report in February 2013, it was determined that an additional effort was needed to address the size and weight of agricultural transport vehicles.

The Phase II report issued by the IoH Study Group is the second report focused on IoH in support of farm operations. Value-added transport and other agricultural commodity transport issues will be taken up by a broader group which may include those who have participated and supported the IoH Study Group's efforts to date. Further discussion and development of the broader initiative to address any issues not resolved by July 31, 2013 is needed.

IoH Study Group Creation: Due to law enforcement and maintenance authorities' response to the rapid increase in size and weight, the Wisconsin Department of Transportation (WisDOT) agreed to fulfill the long standing request by the agricultural industry to form a task force. The interested parties were invited to participate in a kick-off meeting in October 2012. It was determined that the initial focus would be on IoH in support of the farming operation. Other agriculture commodity transport, such as value-added transport, will be addressed at a later time. The IoH Study Group is comprised of:

- Wisconsin Department of Transportation
- Wisconsin Department of Agriculture, Trade, and Consumer Protection
- UW Center for Agricultural Safety and Health
- UW-Madison Department of Biological Systems Engineering
- UW-Extension Environmental Resource Center
- Wisconsin Traffic Operations and Safety Laboratory
- Private Industry:
 - Professional Nutrient Applicators Association of Wisconsin
 - Wisconsin Farm Bureau Federation
 - Professional Dairy Producers of Wisconsin
 - Wisconsin Towns Association
 - Wisconsin County Highway Association
 - Maxville Truck and Repair
 - Wisconsin Custom Operators
 - League of Wisconsin Municipalities
 - Wisconsin Agri-Business Association
 - Husky Farm Equipment (Ontario, Canada)
 - Association of Equipment Manufacturers (Milwaukee, Wisconsin)
 - Dairy Business Association
 - Wisconsin Independent Business – Agri-Business Coalition
 - RCI Engineering LLC
- Equipment Manufacturers:
 - John Deere
 - Kubota Tractor Corporation
 - Case New Holland (CNH)
 - AGCO

IoH Study Group Goals and Objectives: The first goal of the IoH Study Group was to examine the current statutory definitions of IoH in Wisconsin law and determine if there are any policy conflicts. The objective was to classify IoH into categories including CMV converts. The next goal was to develop equipment profiles of IoH that are potentially causing size and weight concerns on roadways, bridges, and culverts. The objective of reviewing size and weight regulations of IoH is to produce an overview of implement-by-implement impacts to be used in potential public policy discussions regarding size and weight. Lastly, identify and propose interim solutions and recommendations to deal with the continuing business needs of the agricultural industry while the aforementioned goals and objectives are vetted by the IoH Study Group.

Role of IoH Work Groups: In an effort to assist the IoH Study Group in achieving its goals and objectives, IoH Work Groups were created to provide initial recommendations. The IoH Work Groups were comprised of IoH Study Group members. The three IoH Work Groups that were established are the IoH Equipment Work Group, the IoH Manure & Other High Frequency Loads Work Group, and the Education & Outreach Work Group. An IoH Engineering Sub-Group was formed to analyze size and weight of IoH and this sub-group reported to the IoH Equipment Work Group.

IoH Study Time Frame: During Phase II of the study, the IoH Study Group focused on:

- Gaining a better understanding of the needs of agriculture, more specifically related to operation of IoH on or across public roads;
- Providing information about the physical and operational constraints related to the public road network;
- Soliciting and reviewing best practices related to operation alternatives or interim solutions, while engineering analysis of weight is conducted;
- Looking for opportunities to better meet the needs of agriculture in the near term through potential legislation or policy adjustments.

The IoH Study Group held meetings on:

- March 8, 2013
- April 12, 2013
- May 10, 2013
- June 14, 2013
- July 8, 2013
- July 26, 2013

The IoH Work Groups held multiple meetings ranging from March 1st, 2013 through July 26th, 2013.

The IoH Study Group committed to producing this Phase II Report providing recommendations to the WisDOT Secretary. This Phase II Report also highlights efforts that will require additional time and review and proposes to permanently establish an agricultural initiative that will be charged with addressing broader agricultural transport issues in support of farming operations in Wisconsin.

IoH Website: The IoH website can be found by visiting:

<http://www.dot.wisconsin.gov/business/index.html>. This website contains IoH Study Group documentation from Phase I and Phase II of the IoH Study.

Role of Engineering

Overview: The IoH Study Group was formed to address the size and weight issues and other concerns presented by the agricultural industry. Many of the issues surrounding size and weight were first identified in the Phase I report. As a result, an engineering sub-group or focus group was formed to examine and analyze some common agricultural vehicles in operation on Wisconsin roadways. The engineering sub-group was comprised of WisDOT pavements and structures engineers. The engineering sub-group began analyzing the size and weight of the identified agricultural vehicles by the IoH Study Group and Equipment Work Group in March 2013. By early July 2013 the engineering sub-group was able to provide the IoH Study Group with some preliminary engineering-based recommendations.



The above images highlight some of the possible effects of heavy IoH on pavements.

Pictures courtesy of Kevin Erb, UW-Extension

Pavement & Bridge Design Factors

Overview: Engineers design roads to accommodate projected vehicle loads; in particular, heavy vehicle axle loads. The life of a pavement is related to the magnitude, number of repetitions and spacing of heavy axle loads. There are instances where IoH can exceed Wisconsin weight laws. However, studying the effects of IoH weights on roadways and structures has been limited to date.

Pavements

Wisconsin road users enjoy having many paved roads unlike Wisconsin's immediate neighboring states. Wisconsin is home to 11,800 miles of state and interstate highways and 103,000 miles of county highways, town and municipal streets. The nearly 115,000 miles of state and local roadways are maintained by the respective jurisdictional agencies. The average width of paved roadways in Wisconsin ranges from 18' (feet) to 24' (feet) from edge of pavement to edge of pavement with most town roads between 20' (feet) and 22' (feet).

Pavement designers consider the amount, type and weight of the traffic using the road. This data is used to calculate an equivalent single-axle load (ESAL – pronounced “easel”) factor; this factor is a way of measuring the impact that a vehicle will have on a pavement.

Pavements should be viewed as a “consumable” and are designed to carry an estimated number of ESALs over their design life. As a heavy load passes over a pavement, a portion of its life is consumed. Eventually, a pavement's life is expended, and it needs to be reconstructed.¹

Engineers forecast the traffic that will travel over a roadway during its design life. This traffic is then used to calculate a design ESAL. If the actual traffic volume and/or vehicle weights exceed forecasts, the roadway's “actual” life will be less than its design life. Over the past decades, both traffic volumes and vehicle weights have increased dramatically.



ACTUAL MEASURES: *The WisDOT engineers analyzed the equipment identified by the MnROAD Study. The MnROAD Study used portable scales to measure the weight of all study vehicles at the start of each test period, as with this double-axle applicator. The MnROAD Study suggested it was one of two applicators tested that produced some of the highest stresses and strains recorded.*

Image courtesy of the MnRoad Study.

If vehicles are overloaded, the damage to the pavement is severe and exponential. This results in a reduced pavement life. As shown below, if all vehicles were 20% overweight, pavement life is cut in half.¹

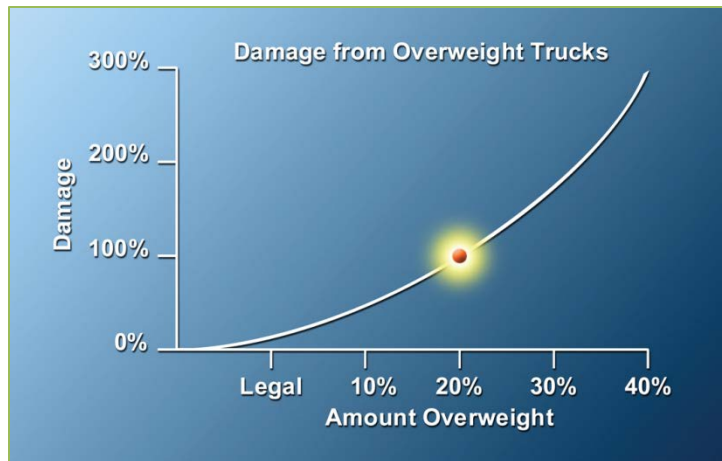

“The load equivalency factor increases approximately as a function of the ratio of any given axle load to the standard 18 kip single axle load raised to the fourth power.” – AASHTO Guide for Design of Pavement Structures, 1993 Edition.

The effect of large and heavy equipment on pavements is not constant throughout the year.¹ During the winter, when the ground is frozen, a truck carrying a given load causes less damage to pavements than at other times of the year. During the spring, the inverse is true: pavement structure layers are generally in a saturated, weakened state due to partial thaw conditions and trapped water, causing greater pavement damage by the same truck. *During spring thaw, Wisconsin restricts heavy loads greater than 80,000 lbs. on roadways.*

In Wisconsin, weight limits have been written into state statute (Chapter 348.15) in an effort to protect our significant investment in transportation infrastructure. All roadways are class “A,” unless the maintaining authority has posted as class “B.” Class A roadways have a maximum single axle weight allowance of 20,000 lbs. when the vehicle has appropriate axle spacing – meaning a distance of 10’ (feet) between foremost and rearmost axles of a group. Class B roadways allow 60% of axle weight allowed on class A roadway. Other weight restrictions might be imposed by local and municipal roadways (348.17 & 349.16).

Bridges

Wisconsin has a known inventory of more than 14,000 bridges that are maintained by the respective jurisdictional agencies. By Federal Highway Administration (FHWA) definition, a bridge has a minimum clear span length of 20 feet between the faces of abutments.

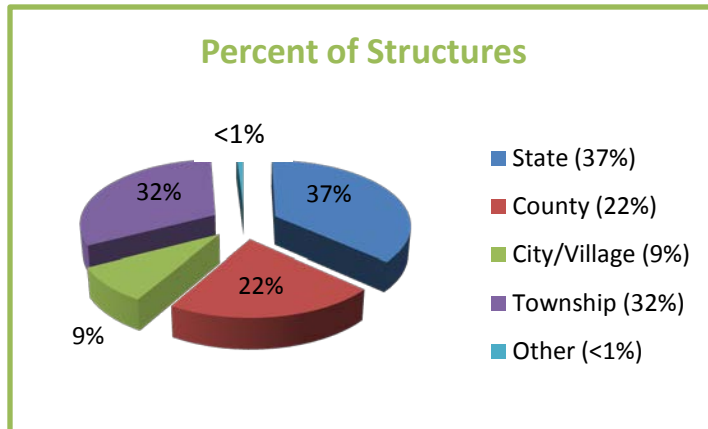

- Number of Structures in Wisconsin
- 14,022 bridges (over 20' in length)
 - 5196 State Owned (37%)
 - 8803 Locally Owned (63%)
 - 7159 "C" Culverts (< 20 ft.)

As previously mentioned, a Federal Bridge Formula was created in an effort to protect roadways and structures. The Federal Bridge Formula has two key components:

- The Federal Bridge Formula establishes the maximum weight any set of axles on a motor vehicle may carry on the Interstate highway system.
- It identifies and limits the weight-to-length ratio of a vehicle crossing a bridge. This is accomplished either by spreading weight over additional axles or by increasing the distance between axles.

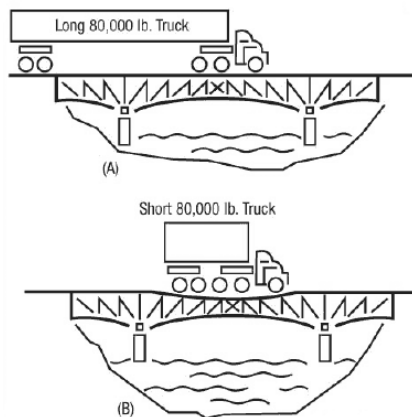

Axle spacing is as important as axle weight in designing bridges. In the picture to the left, the stress on bridge members as a longer truck (A) rolls across is much less than that caused by a short vehicle as shown in B, even though both trucks have the same total weight and individual axle weights. The weight of the longer vehicle is spread out, while the shorter vehicle is concentrated on a smaller area.

Image courtesy of:
www.ops.fhwa.dot.gov/freight/publications/brdg_frm_wqhts/index.htm.

Traditional bridge design and rating is based upon highway-type trucks. Agricultural vehicles have atypical wheel spacing, gauge widths, suspension systems, etc. that requires separate analysis.

An area of concern related to structures is the number of bridges already posted on secondary roads. These local bridges are load restricted as a result of condition and obsolescence.

Heavy IoH are not designed to meet local road and bridge size and weight requirements. However, studying the effects of IoH weights on roadways and structures has been limited to date.

Equipment manufacturers have stated that IoH and agricultural equipment are being designed and manufactured for optimal field performance with no existing requirement to conform to the size and weight laws in Wisconsin and perhaps other states.

Culverts

Another challenge to continued operations on local roadways and bridges is the large number of culverts under roadways. A culvert can resemble a bridge with similar features and characteristics, but is less than 20 feet long from abutment to abutment. Culverts can also be fixed metal or precast/concrete pipes or chutes. Culverts, unlike bridges, are not inventoried or even inspected in the same manner as state, county, and local bridges.

Load Postings in Wisconsin

- State - 58 bridges (1.2%)
- Local - 803+ bridges (9.1%)

Culverts are simply defined as a structure that is less than 20' in length.

- State System - Rough estimate would be 50,000+ structures.
- Local System - Rough estimate would be 86,000+ structures.

¹<http://www.lrrb.org/media/reports/RoadsLoadsDVDBrochure.pdf>.

Analyzed Equipment

The IoH vehicles included for analysis were taken from the April 2012 entitled, “Effects of Implements of Husbandry (Farm Equipment) on Pavement Performance,” also known as the “MnROAD Study,” and the WisDOT pavement and structures engineers specifically examined the following metrics from the MnROAD Study:

- Axle Spacing
- Front & Rear Axle Weights
- Tire Width
- Wheel Base
- Tire PSI
- Tire Contact Area

An analysis of these metrics framed the engineer’s decisions. For more detailed information on each of the IoH vehicles please reference the IoH specifications found in Appendix F & G.

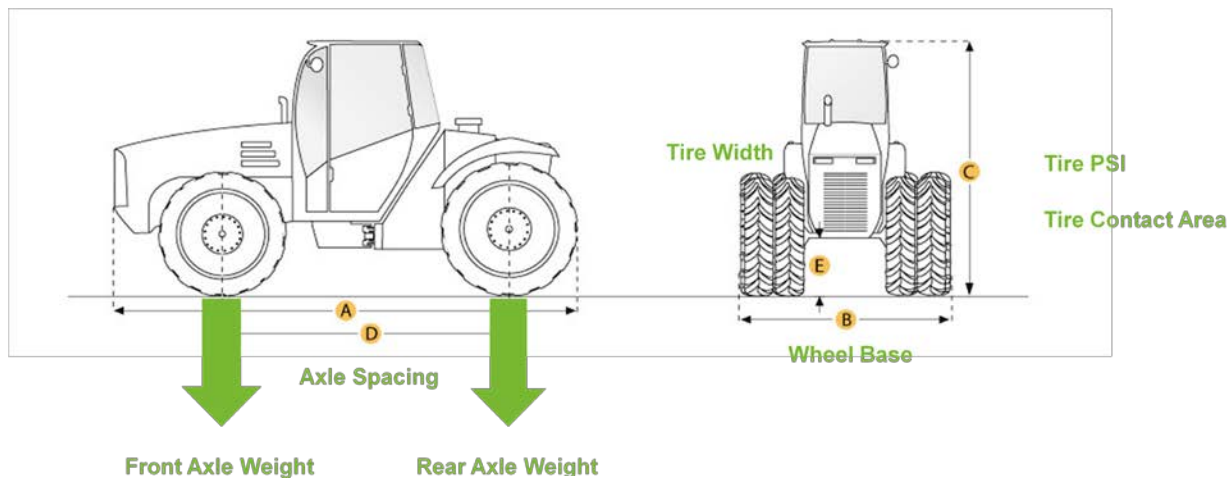

Image courtesy of: <http://www.ritchiespecs.com>.

Flexible Pavements

Pavement responses are influenced by axle loads, environmental effects, pavement structure, and vehicle wheel path. Preliminary analysis from the “Effects of Implements of Husbandry (Farm Equipment) on Pavement Performance,” also known as the “MnROAD Study,” showed that the transverse locations of the vehicles’ wheel path affects which axle was responsible for the maximum pavement responses:

Asphalt strain responses were consistently lower in the spring compared to the fall season. However, observations showed now strong correlation between subgrade stresses and seasonal changes. Testing performed in the morning resulted in lower asphalt strains and subgrade stresses compared to testing performed in the afternoon. Agricultural vehicles loaded at 80%

and 100% load levels recorded large subgrade stresses compared to the control vehicle (an 80,000 lb. semi-trailer) during testing in both spring and fall seasons. Asphalt strains generated by the agricultural vehicles in the spring test recorded higher asphalt strains than the 80,000 lb. semi-trailer. However, testing conducted in the fall seasons resulted in the 80,000 lb. semi-trailer producing larger asphalt strains compared to the tested agricultural vehicles.²

Thicker asphalt and base layers resulted in lower asphalt strain and subgrade stress responses. Additionally, the absence of a paved shoulder greatly increased both asphalt strain and subgrade stress measurements as the vehicles' wheel path approached the pavement edge. Analysis showed that an increase in gross vehicle weight resulted in an increase in pavement responses. *No significant benefits were observed between floatation tires and radial tires in pavement responses.* Preliminary analysis showed no significant effect of the range of tested vehicle speed.²

Teckscan measurements showed that the agricultural vehicles' contact areas increased as axle weight increased. The increase in average contact areas was not significant as the contact area increased from an increase in axle weight.²

Based on the aforementioned conclusion from the MnROAD Study, there is no significant difference between radial and floatation tires on asphalt or subgrade. It is also important to note that impact of the radial tires and floatation tires were only examined on the 4,400 gallon straight truck (commercial motor vehicle, the S4 and S5 category III vehicles identified on page 19) and not the impact of different tire types on other IoH, such as manure tankers, tractors, or self-propelled IoH.

Flotation tires make a huge difference in the field itself (on soil), because the entire tire surface (even the bottom of the treads) is in contact with the soil - as the weight is distributed very evenly when this happens. When examining the compaction diagrams, the concentric circles going out from the tire/soil contact point (<http://extension.missouri.edu/explore/images/g01630art01.jpg>) can be seen (image to the right).

With asphalt pavement, the pressure curves are completely different, and then change direction at the asphalt/gravel interface and again at the gravel/soil interface. The charts in the MnROAD Study show strain and stress occurring 16+ inches away from the tires in both subgrade and asphalt; whereas with soil, the compaction at the soil surface only goes out an inch or less (wider deeper down, as the image to the right shows).

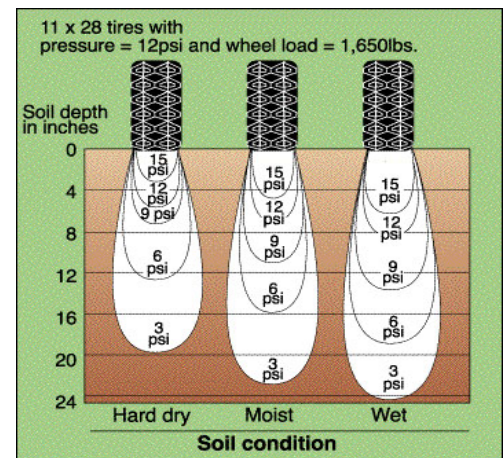







²<http://www.dot.state.mn.us/research/documents/201208.pdf>.





IoH Categories

For the purposes of this study, the roadway, pavement, structure, and implement engineers grouped equipment into four categories as identified in the Phase I report. The categories of equipment are as follows:

Category I (IoH – Primes): A multi-purpose farm tractor designed and used to tow farm equipment, with or without fully-mounted or semi-mounted equipment attached.

<u>Vehicle ID</u>	<u>T1</u>	<u>T2</u>	<u>T6</u>	<u>T7</u>	<u>T8</u>	<u>G1</u>
Vehicle Make	John Deere 8430	M. Ferguson 8470	John Deere 8230	Case IH 275	Case IH Steiger 485	Case IH 9340
Image of Vehicle						







Category II (Self-Propelled IoH): Limited purpose self-propelled equipment designed to perform an agricultural function such as harvesting of crops, for example a self-propelled combine or self-propelled forage chopper.

<u>Vehicle ID</u>	<u>N/A</u>	<u>S3</u>	<u>R4</u>	<u>R5</u>	<u>R6</u>
Vehicle Make	John Deere Forage Harvester 7980	AGCO Terragator 8204	AGCO Terragator 9203	AGCO Terragator 8144	AGCO Terragator 3104
Image of Vehicle					

Category III (CMV Converted IoH): A self-propelled commercial motor vehicle chassis with features designed for farm activity and used exclusively for farm activity.

<u>Vehicle ID</u>	<u>S4</u>	<u>S5</u>
Vehicle Make	Homemade Truck	Homemade Truck
Image of Vehicle		

Category IV (IoH Trains): An agricultural vehicle train defined as a farm tractor towing one or more non-powered farm vehicles (i.e. trailers or manure tanks).

<u>ID</u>	<u>T1</u>	<u>T2</u>	<u>T6</u>	<u>T7</u>	<u>T8</u>	<u>G1</u>
Make	John Deere 8430 w/ Houle Tank	M. Ferguson 8470 w/ Husky Tank	John Deere 8230 w/ Husky Tank	Case IH 275 w/ Houle Tank	Case IH 485 w/ Houle Tank	Case IH 9340 w/ Parker 938 Cart
Image						

Each of these four categories of IoH were created by the IoH Study Group in the Phase I report in an effort to update the definition of “implements of husbandry” to accommodate current farming operations. Although IoH have become larger and heavier in recent years, law enforcement recognizes these pieces of equipment must still operate by abiding by Wisconsin weight guidelines established in statute. Many IoH and CMVs designed for agricultural use are not consistent with Wisconsin law; thus, the IoH Study Group was formed to assist in addressing weight related issues concerning the above agricultural equipment types.

With that said, the above list of IoH is not absolute. The recommendations found within this report will apply to all IoH, regardless if it is mentioned in the above list of IoH or not. Within the time constraints of this study, not every piece of IoH could be examined. As a result, the most accessible data was used from the MnROAD Study for this study. There is still an opportunity for additional research on IoH. Any additional research from a regional or national level could assist in obtaining additional IoH data and provide an opportunity for a more robust study of IoH.

Images in this section are courtesy of the MnRoad Study.

Engineering Analysis

A definitive quantitative analysis that addresses the impacts of IoH or that makes a correlation of IoH to current written authorization options for a variety of vehicles is a major undertaking. The IoH Study Group was able to produce preliminary engineering analysis over the course of four months (March 2013 through June 2013).

The engineers were able to relate distribution factors of the loading for each of the IoH vehicles identified in this Phase II report. In addition they were able to analyze specific routes and unique bridges on these routes to determine if the impacts of the IoH on the structures would be detrimental. Within the tight timeframe of the study, the engineers were able to study the magnitude, repetitions and spacing of axle weights of vehicles and the effects on pavements and structures.

Although there are some remaining research needs, roadway, pavement, structure and implement engineers worked together to create list of equipment specifications to analyze based agricultural vehicles identified in the April 2012 “Effects of Implements of Husbandry (Farm Equipment) on Pavement Performance” also known as the “MnROAD Study” by the Minnesota Department of Transportation. This 551-page report, served as a basis for the engineering sub-group:
<http://www.dot.state.mn.us/research/documents/201208.pdf>.

Pavement: The process for structural analysis included using Asphalt Institute’s SW-1 software. This software allowed pavement engineers to use a layered elastic (mechanistic) method for examining pavements.

From a damage analysis standpoint in relation to pavement performance, the pavement engineers used Miner’s Rule of accumulated damage which has two major components:

- Accounts for multiple loading applications, and
- Is the summation of appropriate accumulated damage units (for each loading case).

The above components were analyzed using the SW-1 Structural Analysis inputs. Other factors considered by the pavement engineers in their analysis included:

- Weather
- Subgrade material properties
- Pavement structures
- Common structure types include:
 - 3-inch CMA over 6-inch base
 - 5-inch CMA over 12-inch base
 - 3-inch HMA over 9-inch base
 - 6-inch HMA over 18-inch base
- Pavement structure material properties

The SW-1 Structural Analysis was used to evaluate all four of the IoH categories defined. The MnROAD Study provided axle weights and tire contact pressure which were important components for evaluating the impact of IoH weight on pavement performance. The IoH vehicles examined produced 40 different axles loadings, but only one vehicle travel speed was used (10 mph).

Bridges: The evaluation process for each of the IoH vehicles identified in this Phase II report and from the MnROAD Study included:

- Evaluation of the vehicle based on the Federal Bridge Formula. It must be noted that though a useful tool, the Federal Bridge Formula was intended for vehicles with standard tire widths and gauges; these IoH vehicles fall outside those parameters.
- Analysis of the moment (bending) and shear demands of these vehicles on approximately 12,000 structures with various span configurations. These demands were then compared to the demands of various design and posting vehicles to determine their relative impact.
- Analysis of approximately 9000 State and Local bridges to determine their safe load-carrying capacity with respect to these particular vehicle configurations. The sampling of bridges analyzed was limited to the three predominant configurations; concrete slab, pre-stressed concrete girder, and steel girder with a number of assumptions on load distribution.
 - Only bridges with span lengths over 20 feet were evaluated. Impacts on culverts were not analyzed.



Image courtesy of the MnRoad Study.

Engineering Analysis Recommendations

Both pavement and structure engineers examined each of the IoH vehicles loaded and unloaded based on the specifications found within the MnROAD Study. Studying both the loaded and unloaded vehicles provided the engineers with pavement deflection data and other results, which were used to craft the following engineering recommendations:

General Recommendations

- Based on a review of the four categories and specific combination within these categories, if an allowance is granted that IoH vehicles were allowed to operate up to 15% over current legal load limits, the impacts to pavement and road infrastructure would be manageable.
- Most of the Category I – Primes can operate without written authorization with exception as noted below for the T8 type Prime.
- Category II Self Propelled should not be allowed to operate without written authorization in the “loaded configuration” due to impacts on both pavements and structures. A few (Forage Harvester, S3, and R5) of Category II IoH as noted below may be able to operate without written authorization in the unloaded configuration. Impacts to pavements were the governing concern.
- Category III CMVs could operate in the unloaded configuration without concerns to pavements and bridges. The Loaded Category III vehicles are too heavy for pavements and bridges.
- Category IV is generally acceptable to run in the unloaded configuration without written authorization with the exception of the T8 that is too heavy based on the pulling tractor. The only loaded configuration that appears to be acceptable is the T2 without written authorization. Loaded configurations have high impacts to both pavements and bridges.

Category I - Recommendations: Based on evaluation results, the following is recommended:

- The T1, T2, T6, T7 and G1 tractors could most likely be allowed to operate without written authorization on the Wisconsin road and bridge inventory without significant regulation related to weight.
- The T8 tractor is a more severe vehicle and would most likely require written authorization to operate on the Wisconsin bridge inventory. The T8 exceeds the Federal Bridge Formula by 38% on a single axle and may produce significant damage to pavement structure. Impact on pavements is the most critical aspect of this implement.

Category II - Recommendations: Based on evaluation results, the following is recommended:

- The John Deere Forage Harvester in the unloaded configuration without the head does exceed the Federal Bridge Formula by 10%, but represents a low impact to pavements and an acceptable impact to bridges. For the self-propelled forage harvester, operation on roads without the head should produce near legal loading.
- The S3 and R5 vehicles could most likely be allowed to operate on pavements and bridges in the unloaded configuration. Both the S3 and R5 are too heavy for bridges in the loaded

configuration - with the S3 exceeding the Federal Bridge Formula by 45% and the R5 exceeding the Federal Bridge Formula by 53%

- The R4 in the unloaded configuration is too heavy based on impacts to pavement structure. The unloaded R4 exceeds Federal Bridge Formula by 19%. The loaded R4 is in excess of the Federal Bridge Formula by 106% and represents a high impact to pavements and medium impact to bridges.
- R6 in the unloaded configuration exceeds Federal Bridge Formula by 21% and is too heavy based on impacts to pavement structure. The loaded and configuration of the R6 vehicle exceeds Federal Bridge Formula by 144% and is not recommended for use without written authorization on the Wisconsin pavement and bridge inventory.
- This category should not be allowed to operate in a loaded configuration on roads without written authorization. Impact to pavement structure was the highest concern with moderate concern to the impact on bridges with the exception of the R6 that produced high impacts to bridges as noted.

Category 3 - Recommendations: Based on evaluation results, the following is recommended:

- This category can run without written authorization in the unloaded configuration.
- The loaded configuration of these vehicles exceeds the Federal Bridge Formula by over 26% and is too severe for pavements and bridges. The S4 and S5 vehicles could most likely be allowed to operate on the Wisconsin pavement and bridge inventory with some modification of the vehicle configuration or with written authorization or in the form of postings to protect bridges in the inventory that do not have adequate capacity to handle these loads.

Category 4 - Recommendations: Based on evaluation results, the following is recommended:

- With the exception of the T8, these can run without written authorization on the roads and bridges in the unloaded configuration. For the T8, the T8 tractor controls the impact in the unloaded configuration and is not advised per Category I.
- The T2 combination is 8% over of the Federal Formula and is the least severe vehicle in this category. The T2 could possibly be allowed to operate without written authorization on pavements and bridges. Written authorization or postings may be required in order to protect bridges in the inventory that do not have adequate capacity to handle this loading.
- The loaded T1, T6, T7, T8 and G1 tractors are too severe for use without written authorization on the Wisconsin Bridge Inventory.

Note: It must also be stressed that bridges deterioration accelerates when subjected to heavy vehicle loads. The long-term maintenance effects should be taken into account when preparing IoH legislation.



Image courtesy of the Wisconsin Department of Transportation

Additional Engineering Research Needs

Within the tight timeframe of the study, the engineers were able to study the magnitude, repetitions and spacing of axle weights of vehicles and the effects of pavements and structures. Studies by Iowa and Minnesota DOTs have produced similar findings in respect to damage and reduced lifecycles. The engineering analysis recommended by the engineering sub-group is preliminary and some additional research is still needed. The additional research needs include:

- Distribution factors related to IoH type equipment to be used in the analysis of bridges;
- Impact factors related to IoH type equipment to be used in the analysis of bridges;
- Design code provisions for the inclusion of the effects of IoH on the design of new structures; and
- Methods to retrofit existing structures that were designed with lower load configurations or have experience deterioration that has reduced the load capacity of the structure below the needs of IoH equipment.

Although there are some remaining research needs, roadway, pavement, structure and implement engineers worked together to create list of equipment specifications to analyze based agricultural vehicles identified in the April 2012 “Effects of Implements of Husbandry (Farm Equipment) on Pavement Performance” or “MnROAD Study” by the Minnesota Department of Transportation. This 551-page report, served as a basis for the engineering sub-group.

It is also important to note that there will be future reports focused on analyzing the effects of IoH on pavements and structures. Here is just one recent example:

- Iowa State University is currently conducting a study on “The Effects of Implements of Husbandry Farm Equipment on Rigid Pavement Performance.”
 - This research is scheduled to provide insights by 2015.
 - The results of the study have not been publicized, but an initial report on the Iowa State University study can be found here:

<http://www.topslab.wisc.edu/workgroups/ioh/resources/viewcontent.pdf>.

Additional Research Opportunity: Roadway, pavement, structure, and implement engineers have an opportunity to supply one another with the necessary information in order to continue the process of analyzing infrastructure impacts from IoH in an effort to develop national and international equipment standards. Also, the studies produced from MnROADS, Iowa State University, and this Phase II report may provide a basis for larger IoH pooled-fund studies both regionally and nationally.

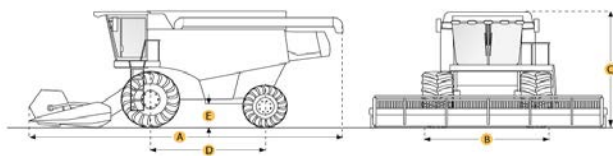

Image courtesy of: <http://www.ritchiespecs.com>.

Best Practices – Manure Hauling & Other High Frequency Divisible Loads

Overview: The IoH Phase I report highlighted several potential best practices. The goal was to highlight possible educational issues where WisDOT, counties, and towns could collaborate with other stakeholders to advocate for improved agricultural vehicle movements and alternative transport on Wisconsin roadways and structures. During Phase II, the IoH Study Group suggested some additional best practices associated with manure hauling and other high frequency divisible loads.

Proactive Steps: The goal of WisDOT and external stakeholders is to extend the life of roadways while sustaining a profitable agricultural system and minimizing inconvenience to road users. Some potential best practices and proactive solutions identified by the IoH Study Group for the Phase II report include:

- Use of off-site or satellite manure facilities
- Vehicle configuration (longer hitch & addition of axles)
- Emerging Innovations for Manure Management
- Trailer Equipment
- Accommodation of Pipelines

Use of off-site or satellite manure facilities: Applicators and farmers could utilize “nurse trucks” and permanent off-site manure facilities in an effort to avoid using heavier IoH on the transportation infrastructure. Some manure applicators and farmers move material from farm to field by transferring loads from a tanker or “nurse truck” on the road to spreaders in the field. This might assist in reducing and avoiding the need to operate heavier IoH on roadways.

What might be considered a low-frequency solution is to have applicators and farmers establish off-site or satellite manure facilities located by nearby fields. Using off-site manure facilities is another best practice for avoiding the need to operate fully loaded divisible IoH on roadways. Depending on the farming operation the most practical best practice might be to utilize “nurse trucks” as manure hauling may only require transporting large quantities of material over the roads in a few concentrated days throughout the year.



Image courtesy of the Wisconsin Department of Transportation.

Vehicle Configurations: Changing an IoH vehicle configurations can be a costly endeavor, but could provide as another low-frequency solution in an effort to protect the local transportation infrastructure.

Some applicators and farmers have reconfigured their agricultural equipment by extending the hitch on trailered equipment. Extending the hitch has the potential to decrease the stress from the rear axle of the motoring unit on pavements and structures.

Some manure haulers and farmers are retrofitting their equipment to mitigate potential weight concerns by adding an axle. Again, this is a low frequency solution because it is an expensive proposition as it increases hauling costs. However, adding an axle can eliminate some of the damage caused by some of the larger and heavier loH.

Emerging Innovations for Manure Management: Support further collaboration between WisDOT, DATCP, and DNR to support the development of emerging practices of manure management, such as:

- Underground transfer pipelines.
- Installation and use of agricultural wastewater systems.
- Use of center pivot irrigators and sprinkler systems for liquid manure application.
- Use of low-trajectory, low-pressure systems (drop nozzles) on existing manure applicator systems.
- Use of anaerobic digesters for the conversion of manure into bio-gas or compressed natural gas (CNG) to fuel dairy and agricultural vehicle fleets.

Trailer loH Vehicles: Another potential best practice to use for extremely large and heavy loH is to trailer this equipment from farm to field. Trailering heavy loH will help reduce the stress caused to pavements and structures.



Image courtesy of: <http://siouxlandtrailersales.com/>.

Accommodation of Pipelines: The accommodation of pipelines was highlighted in the Phase I report, but is being reinforced in this Phase II report. Liquid manure transport typically involves very heavy vehicles in configurations that put excessive stress on highway infrastructure, often when roadways are unable to reasonably handle these loads. Seeking to overcome obstacles so that pipeline transport is viable could avoid infrastructure damage and highway operational issues while allowing large application equipment to operate as designed and avoiding impacts of seasonal road weight limits. The goal of this best practice is to improve efficiency of transport while preserving highway infrastructure by using pipelines when feasible.

Wisconsin farmers are increasingly dealing with liquid manure that needs to be transported from collection and storage tanks or lagoons to fields where it is applied. Transport is time sensitive and often is impacted by weight limitations due to thaw conditions. Pipelines are a means of transporting liquids that can avoid road use, but are sometimes not workable due to limitations on accommodation of the lines to cross public rights of way. The IoH Study Group has identified the following possible solutions regarding accommodation of pipelines to support transport of liquid manure:

- Promote consideration of crossings by sharing information about WisDOT permit practices.
- Propose statutory changes to clarify and highlight permit potentials for these crossings.
- Propose statutory changes that also provide authority for longitudinal accommodation.

Although the IoH Study Group has identified the above possible solutions, the IoH Study Group recommends:

- Proposing statutory changes that also provide authority for longitudinal accommodation. Create broad authority to issue permits to accommodate pipelines for liquid manure/nutrients including longitudinally in right of way when need is demonstrated, under specific conditions.

Centerline Movements: Larger and wider agriculture equipment made to be efficiently used in the field, in turn makes several types of equipment wider than highway lanes. Although State Statute 348.05 (2) & (3) provides specifics of operation of these pieces of equipment upon the highway, there is no ruling that legally allows over-width equipment to operate left of center on any state highway. Best practices are needed for safe and efficient over-width agriculture equipment movements.

The IoH Study Group has identified the following possible solutions regarding centerline movements:

- Set specific width threshold for traveling highways.
- Require all oversize IoH equipment to be hauled on CMV units and trailers.
- Allow current standards, but require a warning vehicle to travel in front and/or behind during highway travel depending on overall width.

Identify Problem Areas & Solutions: The following list of best practices was highlighted in the Phase I report, but is being reinforced in this Phase II report. Farmers and local governments can partner to solve identified problems areas. Some possible solutions to common and identified problems are to:

- Invest in high quality subgrade where stress is often the greatest due to acceleration/deceleration of vehicles or turning of vehicles in intersections and driveways.
- Pave shoulders at turning points to avoid pavement erosion.
- Invest in longer culverts at field and farm driveways with paved shoulders.
- Invest in curb and gutters to protect pavement edges and allow for proper water drainage.
- Utilize town or county TIF districts (tax incremental finance districts) which could lead to infrastructure improvements mainly due to an increased tax base.
- Implement one-way traffic strategies to increase the number of hours needed to haul feed, manure, or other agricultural means during seasonal agricultural operations.
- Use piping or hoses to transfer agricultural material near right of way or culverts of roadways.

Review of Wisconsin Statutes

IoH Definition

Overview: Current definitions of Implements of Husbandry (IoH) in Wisconsin statute (Chapters 340, 341, and 348) do not provide for clear distinction among agricultural equipment types. This results in unclear guidance to road users and enforcement regarding size, weight, operating and safety equipment requirements and restrictions and operator qualifications. Current definitions in Wisconsin statutes of farm tractors and IoH are referred to by statutes regarding size, weight, operation requirements, equipment requirements and operator qualifications and requirements. Current terms need to better reflect the desired distinctions between IoH CMVs and non-CMV agricultural equipment.

Current Structure of Wisconsin statutes: Chapter 340 lists definitions of vehicles that apply to Chapters 341-349, with the following exception: where a separate definition is provided in a chapter within the 341-349 range, then it overrides the definition found in Chapter 340. Specifically, the definition of IoH in Chapter 341 regarding vehicle registration (“license plates”) overrides the definition found in Chapter 340.

For quick reference, here are the chapter topics which relate to the IoH Study Group: Chapter 340 (general provisions and definitions), Chapter 341 (description of vehicle registration – license plates), Chapter 346 (operator requirements), Chapter 347 (vehicle safety and equipment requirements), and Chapter 348 (vehicle size and weight allowances and limitations).

Reviewed Proposals: In order to provide clarity and guidance to road users and law enforcement regarding size, weight, operating and safety equipment requirements and restrictions and other operator qualifications for IoH, the IoH Study Group has identified the following possible recommendations (Note: *The language below is intended to serve as a guide and is not intended to be perceived as the exact proposed statutory language*):

- Clarify the IoH Definition:
 - Create a clearer, simpler definition of IoH to reflect today’s agricultural equipment.
 - Commercial motor vehicles (CMVs) used exclusively for agricultural operations are defined as an IoH CMV.
 - All IoH will be exempt from registration.
 - A self-certification will be available for IoH CMVs.
- Create size limits or an “envelope” for IoH:
 - Width envelope:
 - Width of IoH – 15’ (feet); However, an IoH greater than 15’ (feet), but no greater than 17’ (feet) may be operated without written authorization when the IoH operator meets safety requirements to ensure safe passage by other road users.
 - Width of IoH CMV – 10’ (feet).
 - Height envelope: Height of IoH – 13’6” (feet/inches); However, an IoH greater than 13’6” (feet/inches) may operate without written authorization. The IoH operator is

responsible for ensuring there are no conflicts with over-head obstructions, such as wires or structures.

- Length envelope: 60' (feet) for a single IoH; 100' (feet) for combinations of two IoH; and 70' (feet) for combinations of three IoH.
- IoH is given an expanded 15% weight allowance over the limits as established by the Federal Bridge Formula, except where posted and during periods of spring thaw. This equates to a maximum single axle weight of 23,000 pounds and a gross vehicle weight of 92,000 pounds. A new IoH weight table will be created to (e.g. 348.30) reflect the 15% allowance based on gross vehicle weight, axle weight and spacing.
- Written authorization to exceed the size envelope and weight limits may be requested on an annual basis from the maintaining authority that has roadway. Written authorizations may only be granted when:
 - The operator is 18 years of age and who holds a valid driver's license.
 - IoH meets lighting, marking, and safety requirements pertaining to IoH in s. 347 (safety requirements).
 - A travel or route plan for the IoH is submitted.

Additional conditions may be set by each maintaining authority (local or state) of which the IoH is operating within the context of the written authorization.

- IoH vehicles operating in excess of the 15% allowance will be fined for the amount in excess of standard gross motor vehicle weight or individual axle weight.

Conclusions/summary: Establishing clear definitions of implements of husbandry will assist in determining whether a vehicle, piece of equipment or machinery, or trailer is designed for agricultural purposes and used exclusively in the conduct of agricultural operations. Additionally, clear and concise definitions of implements of husbandry will assist in distinguishing the differences between farm tractors, self-propelled IoH, IoH trains, IoH-CMV's and other non-CMV agricultural equipment for law enforcement and the motoring public.

IoH CMV Identification

WisDOT's Consensus Position: WisDOT would support the self-certification of IoH CMVs rather than creating a decal, sticker, or plate for identification purposes for IoH CMV converted vehicles.

Reasoning: The Wisconsin Department of Revenue suggests that if a plate was recommended an IoH – CMV could no longer operate using dyed fuel because of laws established by Wisconsin and the IRS. However, a decal or sticker could assist in confirming IoH-CMV's can operate using dyed fuels, but the implementation of such a program is problematic.

Revenue from motor vehicle plates in Wisconsin is based on the total scale of motor vehicles. Given the relatively small number of IoH CMVs, the potential to cover the administrative costs of a decal or sticker program may be challenging. In addition, any revenue gained would likely not have strong potential to generate additional revenue that could be targeted to needs related to these uses of public roadways.

WisDOT's is not in the position to create new credentials (decals, stickers, or plates) for IoH CMVs. A new credential would put IoH CMVs into the DMV database. In addition, a new credential could put IoH CMV owners in violation of law and penalized if the IoH CMV owner does not obtain and maintain the credential. Furthermore, a new credential could open-up more questions and could cause more problems for IoH CMV owners. An example question could be: "Who is responsible for an IoH CMV if it is operated by a CO-OP?" Essentially, adding a new credential could potentially disadvantage others and could introduce compliance concerns for IoH CMV owners. Lastly, if the sole purpose of creating a new credential for IoH CMVs is for identification purposes in an effort to avoid potential questions from law enforcement, then the new credential may not necessarily solve this issue as law enforcement will still stop an IoH CMV if in question.

Remedy: The remedy or recommendation by WisDOT has three components:

- 1) An improved definition of IoH CMV converted vehicles would be the first step in clearly identifying IoH CMVs. As a result, it is critical that the drafting instructions associated with the Phase II Report to be clear and concise. Clarifying the statutory definition and simplifying it will assist all stakeholders in better enforcement.
- 2) A clear definition will also lead to an educational component. The ultimate consensus remedy is to have the Education & Outreach Work Group create a self-identification matrix. The self-identification matrix would serve as a self-assessment or checklist. The self-identification matrix would highlight IoH CMV operational requirements (based on agricultural use, etc.). A frequently asked question or FAQ form could also be created by the Education & Outreach Work Group in an effort to help identify (via pictures and text) the differences between CMVs (and requirements) and IoH CMVs (and requirements).
- 3) If a vehicle meets the definition of the IoH CMV, then the IoH CMV owner then could print a self-identifying certification from the WisDOT website. The self-identifying certification would only be for IoH CMV vehicles and this certification could also be created by the Education & Outreach Work Group.

Education & Outreach Efforts

Overview: The IoH Study Group recognizes that stakeholder engagement is a critical component of its work. In addition, simplifying IoH regulations is a goal that has been echoed by various stakeholders. Recognizing this value, an IoH working group was established to focus solely on education and outreach.

Goal: The overall goal of the IoH Study Education and Outreach Work Group is to help all interested stakeholders communicate effectively, based on a clear and common language, a shared knowledge of the science of roads and an understanding of today's agricultural equipment, to include the establishment of IoH CMVs.

In an effort to better educate various stakeholders about IoH, current regulations and the study's recommendations, the IoH Education and Outreach Work Group has been and is in the process of developing education and outreach materials. Some example materials being created include:

- A WisDOT web-page to house resources pertaining to IoH, for access by all stakeholders,
- Comparison of size and weight regulations presently in place in Wisconsin, compared to the study's recommendation,
- Fact sheet illustrating the science behind the capacity of pavement and structures, and
- Feedback tools to continue to gather information to further shape the study's recommendations.

In addition, members of the full IoH Study Group will be reaching out to their members and also participating in "town-hall-style" meetings to gauge stakeholder input in August and September 2013. These efforts are being designed to inform others about the findings in the Phase I and Phase II reports, but also facilitate discussion on the various findings.

In early September 2013, an addendum will be added to this Phase II report highlighting the results of stakeholder feedback.

Next Steps: Upon the completion of any possible legislative action, the Education and Outreach Work Group is committed to creating Wisconsin IoH reference guides for print and electronic distribution, such as the Minnesota guide (right). These materials are to be used as universal educational resources regarding IoH laws, permits and best practices for agricultural producers, local officials and law enforcement.

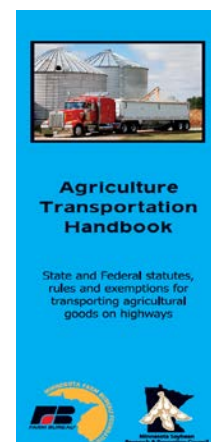

The IoH Outreach and Education Work Group is developing an "Agricultural Transportation Handbook," similar to the pictured (above) Minnesota handbook.

Appendix A: Glossary

Current Wisconsin Statute Definitions:

340.01(7m) "Commercial driver license (CDL)" means a license issued to a person by this state or another jurisdiction that is in accordance with the requirements of 49 USC 31301 to 31317, or by Canada or Mexico, and that authorizes the licensee to operate certain commercial motor vehicles.

49 USC 31301(3) "commercial driver's license" means a license issued by a State to an individual authorizing the individual to operate a class of commercial motor vehicles.

340.01(8) "Commercial motor vehicle (CMV)" means a motor vehicle designed or used to transport passengers or property and having one or more of the following characteristics:

- (a) The vehicle is a single vehicle with a gross vehicle weight rating of 26,001 or more pounds or the vehicle's registered weight or actual gross weight is more than 26,000 pounds.
- (b) The vehicle is a combination vehicle with a gross combination weight rating, registered weight or actual gross weight of 26,001 or more pounds inclusive of a towed unit with a gross vehicle weight rating, registered weight or actual gross weight of more than 10,000 pounds.
- (c) The vehicle is designed to transport or is actually transporting the driver and 15 or more passengers. If the vehicle is equipped with bench type seats intended to seat more than one person, the passenger carrying capacity shall be determined under s. 340.01 (31) or, if the vehicle is a school bus, by dividing the total seating space measured in inches by 13.

340.01(24)(a) - "Implement of husbandry (IoH)" means a vehicle or piece of equipment or machinery designed for agricultural purposes, used exclusively in the conduct of agricultural operations and used principally off the highway, or a trailer-mounted bulk liquid fertilizer container.

340.01(24)(b) - "Implement of husbandry (IoH)" does not include any motor truck, farm truck, road tractor, truck tractor, or farm truck tractor or such a vehicle combined with a semitrailer, trailer or farm trailer, when the vehicle or combination is a commercial motor vehicle operated on a highway.

341.01(2)(a) - "Implement of husbandry (IoH)" means a vehicle or piece of equipment or machinery designed for agricultural purposes, used exclusively in the conduct of agricultural operations and used principally off the highway, or a trailer-mounted bulk liquid fertilizer container.

Appendix B: Infrastructure Information – Height Considerations

Bridge Postings: Wisconsin Manual On Uniform Traffic Control Devices, page 20, from:

<http://www.dot.wisconsin.gov/business/engrserv/docs/wmutcd.pdf>.

Section 2C.27 Low Clearance Signs (W12-2 and W12-2a)

Standard:

(01) The Low Clearance sign (W12-2) sign shall be used at all points where the clearance over any part of the usually traveled portion of the roadway is less than 14' - 6". Where the clearance is less than 13' - 6" an additional sign to that affect shall be placed at the nearest intersection on which a vehicle can detour onto. The appropriate XXX MILES AHEAD plaque (W57-52) shall be added to the advance sign.

On all freeway/expressway interchanges, low clearance signs shall be placed in advance of the exit over height vehicles can use to avoid the low clearance bridge, as well as at the bridge location itself where the bridge clearance is less than 14' - 6".

Guidance:

On oversize/overweight (OSOW) freight network routes, clearances of 14'-6" or higher should be considered for installation of low clearance signs depending on the OSOW vehicles using specific routes and as approved by the region traffic engineer. Low clearance signs should be considered for clearances of 14'-6" or higher on OSOW secondary routes if the secondary route has structure clearances that are less than on the parallel OSOW primary route.

Option:

At the discretion of the maintaining authority of a roadway, troublesome or frequently hit structures with clearances at 14' - 6" and above may be signed.

If a segment of roadway contains a number of structures that are marked for clearances an advance sign may be placed in advance of an exit that would allow an over height vehicle to detour onto another route. If the lowest structure in the segment is below 14' - 6" the sign shall read "Low Clearance Structures next XX Miles". If the lowest structure is 14' - 6" or above the sign shall read "XX' XX" Minimum Clearance next XX miles". Both of these signs shall have a black legend on a yellow background.

Clearances for Electric Overhead Services: Not for primary or secondary clearances; per NESC Table 232-1 and 234-1 and Wisconsin PSC 114. Note that the following are the minimum clearances needed. Additional clearances must be added to account for the thermal loading, ice loading, and snow depth when looking at vertical clearances. All clearances are for services under 750 volts unless otherwise indicated.

<i>Triplex & Quadruplex Cables (most common)</i>	<i>Type A</i>	<i>Rule 230C3</i>
<i>Open Wire Poly Insulated Cables</i>	<i>Type B</i>	

Vertical Clearances	Type A	Type B
----------------------------	---------------	---------------

Roads, Streets, Driveways, Parking Lots, Alleys, Cultivated Land, Grazing, Forest Orchards, etc.

16'	16'5"
-----	-------

If the height of the building to which the service is attached does not permit and there is only a residential driveway (no chance of trucks), under 150 volts to ground, and insulated.

12'	12'5"
-----	-------

Drip Loop	10'	10'5"
-----------	-----	-------

If along roads in rural districts where it is unlikely that vehicles will be crossing under the line (must consider blow out to embankments, etc.).

14'	14'5"
-----	-------

If along rural roads and not located relative to fences, ditches, embankments, etc., so that ground under the line would not be expected to be traveled except by pedestrians, may be reduced to the following: The service must be under 150 volts to ground and insulated.

9'5"	12'5"
------	-------

WisDOT minimum clearances over roadway (only State & Federal Highways)(use NESC if greater than this)(under worst case conditions)(WI Maintenance Manual 96.94)

17'	17'
-----	-----

Section 232 of the National Electrical Safety Code (NESC): Electric distribution neutral wires have a 15'5" (feet/inches) clearance requirement and primary conductors have an 18'5" (feet/inches) clearance requirement. The aforementioned clearance represents the distance between the road and the bottom of the wire. Neutral wires are, in most cases, bare wires. Thus, having adequate clearance is imperative. *Note: While the above heights are standards, not all overhead wires may adhere to these standards. Checking for clearance will be important prior to operating loH.*

Reference Link: http://www.wisconsinpublicservice.com/business/manual/7_1.pdf.

Appendix C: Preliminary Drafting Instructions

Overview: Current definitions of Implements of Husbandry (IoH) in Wisconsin statute (Chapters 340, 341, and 348) do not provide for clear distinction among agricultural equipment types. This results in unclear guidance to road users and enforcement regarding size, weight, operating and safety equipment requirements and restrictions and operator qualifications. Current definitions in Wisconsin statutes of farm tractors and IoH are referred to by statutes regarding size, weight, operation requirements, equipment requirements and operator qualifications and requirements. Current terms need to better reflect the desired distinctions between IoH CMVs and non-CMV agricultural equipment.

Current Structure of Wisconsin statutes: Chapter 340 lists definitions of vehicles that apply to Chapters 341-349, with the following exception: where a separate definition is provided in a chapter within the 341-349 range, then it overrides the definition found in Chapter 340. Specifically, the definition of IoH in Chapter 341 regarding vehicle registration (“license plates”) overrides the definition found in Chapter 340.

For quick reference, here are the chapter topics which relate to the IoH Study Group: Chapter 340 (general provisions and definitions), Chapter 341 (description of vehicle registration – license plates), Chapter 346 (operator requirements), Chapter 347 (vehicle safety and equipment requirements), and Chapter 348 (vehicle size and weight allowances and limitations).

Reviewed Proposals: In order to provide clarity and guidance to road users and law enforcement regarding size, weight, operating and safety equipment requirements and restrictions and other operator qualifications for IoH, the IoH Study Group has identified the following possible recommendations (*Note: The language below is intended to serve as a guide and is not intended to be perceived as the exact proposed statutory language*):

Definition of “Implement of Husbandry (IoH)”:

Recommendation (1): Replace the current statutory definition of IoH, found in s. 340.01(24)(a)&(b), with:

- “Implement of husbandry” means a self-propelled or towed vehicle manufactured, designed, or reconstructed to be used exclusively in the conduct of agricultural operations and used primarily off the highway. An “implement of husbandry” includes a farm tractor, self-propelled application-type vehicles (such as a combine), farm wagon, farm trailer, or trailer adapted to tow or pull another implement of husbandry, or any substantially similar equipment used to transport agricultural products necessary for agricultural production.
- An “implement of husbandry – commercial motor vehicle,” or “IoH-CMV” means a reconstructed or principally designed and manufactured vehicle similar to other highway-use vehicles to be used exclusively in the conduct of agricultural operations and used primarily off the highway is considered to be an implement of husbandry. The term “reconstructed” as used in this subsection means materially altered from the original construction by the removal, addition, or substitution of essential parts, new or used for agricultural purposes. A commercial

motor vehicle – implement of husbandry designed for agricultural purposes and used, even temporarily, for non-agricultural purposes shall not be considered an implement of husbandry.

- The existing definition of “implement of husbandry” found in s. 341.01(2)(a) can be removed. Removing the definition of loH in s. 341.01 will assist in clarifying and simplifying the definition of loH. However, all loH will be exempt from registration and a self-certification will be available for CMVs operating as loH.
- The following terms require no changes: farm tractor (s. 348.01(16)), farm trailer (s. 340.01(17)), farm truck (s. 340.01(18)), and farm truck tractor (s. 340.01(18g)).

Chapter 346.925 “Operator Requirements”

Recommendation (2): Add permit qualifications under 346.925(1) – operator requirements.

- No person may obtain a permit or written authorization, in s. 348.26 and s. 348.27 [e.g. s. 348.27(14)], unless a person is 18 years of age and maintains a valid driver’s license.

Chapter 348.05 “Width of Vehicles”

Recommendation (3): Institute a width envelope for loH.

- Implements of husbandry as defined in s. 341.01(24)(a) will have a width envelope is 15’ (feet); However, an loH greater than 15’ (feet), but no greater than 17’ (feet) may be operated without written authorization when the loH operator meets safety requirements to ensure safe passage by other road users. A reconstructed commercial motor vehicle designed for agricultural purposes, as defined in 341.01(24)(b) as “loH-CMV” shall be no wider than 10’ (feet), which includes tires and any other agricultural attachments.

Chapter 348.06 “Height of Vehicles”

Recommendation (4): Institute a height envelope for loH.

- Implements of husbandry as defined in s. 340.01(24)(a) & (b) will have a height envelope of 13’6” (feet/inches); However, an loH greater than 13’6” (feet/inches) may operate without written authorization. The loH operator is responsible for ensuring there are no conflicts with over-head obstructions, such as wires or structures.

Chapter 348.07 “Length of Vehicles”

Recommendation (5): Institute a length envelope for loH.

- Implements of husbandry as defined in s. 340.01(24)(a) & (b) will have a maximum envelope length of 60’ (feet) for single loH.

Chapter 348.08 “Vehicle Trains”

Recommendation (6): Institute a length envelope for IoH vehicle trains.

- A two (2) IoH vehicle combination will have a maximum length envelope of 100’ (feet). A three (3) IoH vehicle combination will have a maximum length of 70’ (feet). The 70’ (feet) length for three (3) IoH vehicle combinations is to prevent the third IoH from “swaying” on the roadway or structure.

Chapter 348.17 “Special or Seasonal Weight Limitations” - Weight

Recommendation (7): Provide a 15% weight allowance over the limits as established by the Federal Bridge Formula, except where posted and during periods of spring thaw for IoH.

- IoH is given an expanded 15% weight allowance over the limits as established by the Federal Bridge Formula, except where posted and during periods of spring thaw. This equates to a maximum single axle weight of 23,000 pounds and a gross vehicle weight of 92,000 pounds. A new IoH weight table will be created to (e.g. 348.30) reflect the 15% allowance based on gross vehicle weight, axle weight and spacing.
- IoH vehicles operating in excess of the 15% allowance will be fined for the amount in excess of standard gross motor vehicle weight or individual axle weight.

Chapter 348.17 “Special or Seasonal Weight Limitations” - Weight

Recommendation (8): Provide a 15% weight allowance over the limits as established by the Federal Bridge Formula, except where posted and during periods of spring thaw for IoH.

- Written authorization to exceed the size envelope and weight limits may be requested on an annual basis from the maintaining authority that has roadway. Written authorizations may only be granted when:
 - The operator is 18 years of age and who holds a valid driver’s license.
 - IoH meets lighting, marking, and safety requirements pertaining to IoH in s. 347 (safety requirements).
 - A travel or route plan for the IoH is submitted.

Additional conditions may be set by each maintaining authority (local or state) of which the IoH is operating within the context of the written authorization.

IoH Weight Table

Recommendation (9): Create a new weight table to be placed in Chapter 348 for IoH.

- Create a new weight table to be placed in Chapter 348 for IoH (*e.g. 348.30*).
- Reasoning: The engineering analysis for IoH Study is based on the Federal Bridge Formula, thus, for clarity purposes (public and enforcement) a weight table be established for reasonable ease to determine if IoH is legal and is eligible for written authorization.

Conclusions/summary: Establishing clear definitions of implements of husbandry will assist in determining whether a vehicle, piece of equipment or machinery, or trailer is designed for agricultural purposes and used exclusively in the conduct of agricultural operations. Additionally, clear and concise definitions of implements of husbandry will assist in distinguishing the differences between farm tractors, self-propelled IoH, IoH trains, IoH-CMV's and other non-CMV agricultural equipment for law enforcement and the motoring public.

Appendix D: IoH Weight Table

PROVISIONS:

- a. Single axle: 23,000
- b. Patterned after Figure 348.29 and Figure 348.295, Wis. Stats.

Maximum gross weight in pounds on a group of --

Distances in feet between foremost and rearmost axles of a group	2 axles of a vehicle or combination of vehicles	3 axles of a vehicle or combination of vehicles	4 axles of a vehicle or combination of vehicles	5 axles of a vehicle or combination of vehicles	6 axles of a vehicle or combination of vehicles	7 axles of a vehicle or combination of vehicles	8 axles of a vehicle or combination of vehicles
4	39,500	45,000	51,500	58,500	65,000	72,000	79,000
5	40,500	46,000	52,500	59,000	66,000	72,500	79,500
6	41,500	47,000	53,000	60,000	66,500	73,500	80,000
7	43,000	47,500	54,000	60,500	67,000	74,000	80,500
8	44,000	48,500	54,500	61,000	68,000	74,500	81,500
9	45,000	49,500	55,500	62,000	68,500	75,500	82,000
10	46,000	50,500	56,000	62,500	69,000	76,000	82,500
11		51,000	57,000	63,500	70,000	76,500	83,500
12		52,000	57,500	64,000	70,500	77,500	84,000
13		53,000	58,500	65,000	71,500	78,000	84,500
14		53,500	59,500	65,500	72,000	78,500	85,500
15		54,500	60,000	66,000	72,500	79,500	86,000
16		55,500	61,000	67,000	73,500	80,000	86,500
17		56,500	61,500	67,500	74,000	80,500	87,500
18		57,000	62,500	68,500	75,000	81,500	88,000
19		58,000	63,000	69,000	75,500	82,000	88,500
20		59,000	64,000	70,000	76,000	82,500	89,500
21		60,000	64,500	70,500	77,000	83,500	90,000
22		60,500	65,500	71,500	77,500	84,000	90,500
23		61,500	66,000	72,000	78,000	84,500	91,500
24		62,500	67,000	72,500	79,000	85,500	92,000
25		63,000	67,500	73,500	79,500	86,000	
26		64,000	68,500	74,000	80,500	86,500	
27		65,000	69,000	75,000	81,000	87,500	
28		66,000	70,000	75,500	81,500	88,000	
29			71,000	76,500	82,500	88,500	
30			71,500	77,000	83,000	89,500	
31			72,500	77,500	83,500	90,000	
32			73,000	78,500	84,500	90,500	
33			74,000	79,000	85,000	91,500	

Implements of Husbandry Study

Distances in feet between foremost and rearmost axles of a group	2 axles of a vehicle or combination of vehicles	3 axles of a vehicle or combination of vehicles	4 axles of a vehicle or combination of vehicles	5 axles of a vehicle or combination of vehicles	6 axles of a vehicle or combination of vehicles	7 axles of a vehicle or combination of vehicles	8 axles of a vehicle or combination of vehicles
35			75,500	80,500	86,500		
36			76,000	81,500	87,000		
37			77,000	82,000	88,000		
38			77,500	83,000	88,500		
39			78,500	83,500	89,500		
40			79,000	84,000	90,000		
41			80,000	85,000	90,500		
42			80,500	85,500	91,500		
43			81,500	86,500	92,000		
44			82,500	87,000			
45			83,000	88,000			
46			84,000	88,500			
47			84,500	89,000			
48			85,500	90,000			
49			86,000	90,500			
50			87,000	91,500			
51			87,500	92,000			
52			88,500				
53			89,000				
54			90,000				
55			90,500				
56			91,500				
57			92,000				

Appendix E: Example Written Authorization Form

DRAFT: Written Authorization For The Transportation of Implements of Husbandry Of Excessive Size & Weight

Written Authorization number _____ . Issued at _____
(location of local authorizing jurisdiction), Wisconsin on _____ (Date –MM/DD/YYYY).

Issued to (name of operator) _____ by
the Town of _____ in _____ County,
Wisconsin.

Nature of Load: _____.

Make and Model of IoH: _____
_____.

Gross Weight of IoH: _____.

Size of IoH (width, height, length): _____
_____.

Route over roadways: _____
_____.

Special Conditions (check all that apply and write-in conditions as appropriate):

- Maintenance and Repair of Described Route
- Speed limit of _____ (unless posted roadway speed limit is lower).
- No travel on weekends and holidays.
- No travel during hours of darkness.
- Travel only on days of the week listed: _____.
- Travel between _____ AM/PM (circle) and _____ AM/PM (circle).
- Other: _____
_____.

Good in the issuing Township from _____ (date – MM/DD/YYYY) to
_____ (date – MM/DD/YYYY) for:

One Trip or Multiple Trips

(Circle One)

Issued on condition that written authorization holder assumes complete responsibility for all damage resulting from this trip.

Issued By: _____.

Title: _____.

Accepted subject to conditions imposed:

Signature of Written Authorization Holder

Insurance Company Name: _____.





Policy Number: _____.

Expiration Date: _____ (Date – MM/DD/YYYY).





Written Authorization Must Be Carried By Operator.

Appendix F: Engineering Analysis (Equipment Matrix)

Category I: IoH - Primes



IoH Category	Photo	Vehicle ID	Vehicle Make	EMPTY CONFIGURATION					FULLY-LOADED CONFIGURATION				
				Gross Weight	Meets FBF?	Controlling Element for FBF	BRIDGE Impact	PAVEMENT Impact	Gross Weight	Meets FBF?	Controlling Element for FBF	BRIDGE Impact	PAVEMENT Impact
I		T1	John Deere 8430	Total = 30,240 lbs	YES	Axle 2 = 17,300 lbs	LOW	LOW	Total = 30,240 lbs	YES	Axle 2 = 17,300 lbs	LOW	LOW
				Axle 1 = 12,900		87% of FBF			Axle 1 = 12,900		87% of FBF		
				Axle 2 = 17,300 lbs					Axle 2 = 17,300 lbs				
I		T2	M. Ferguson 8470	Total = 21,780 lbs	YES	Axle 2 = 12,700 lbs	LOW	LOW	Total = 21,780 lbs	YES	Axle 2 = 12,700 lbs	LOW	LOW
				Axle 1 = 9,080 lbs		64% of FBF			Axle 1 = 9,080 lbs		64% of FBF		
				Axle 2 = 12,700 lbs					Axle 2 = 12,700 lbs				
I		T6	John Deere 8230	Total = 30,820 lbs	YES	Axle 2 = 17,600 lbs	LOW	LOW	Total = 30,820 lbs	YES	Axle 2 = 17,600 lbs	LOW	LOW
				Axle 1 = 13,220 lbs		88% of FBF			Axle 1 = 13,220 lbs		88% of FBF		
				Axle 2 = 17,600 lbs					Axle 2 = 17,600 lbs				
I		T7	Case IH 275	Total = 32,900 lbs	YES	Axle 2 = 19,020 lbs	LOW	LOW	Total = 32,900 lbs	YES	Axle 2 = 19,020 lbs	LOW	LOW
				Axle 1 = 13,880 lbs		95% of FBF			Axle 1 = 13,880 lbs		95% of FBF		
				Axle 2 = 19,020 lbs					Axle 2 = 19,020 lbs				
I		G1	Case IH 9330	Total = 27,400 lbs	YES	Axle 2 = 14,800 lbs	LOW	LOW	Total = 27,400 lbs	YES	Axle 2 = 14,800 lbs	LOW	LOW
				Axle 1 = 12,600 lbs		74% of FBF			Axle 1 = 12,600 lbs		74% of FBF		
				Axle 2 = 14,800 lbs					Axle 2 = 14,800 lbs				
I		T8	Case IH Steiger 485	Total = 53,430 lbs	NO	Axle 2 = 26,950 lbs	MEDIUM	HIGH	Total = 53,430 lbs	NO	Axle 2 = 26,950 lbs	MEDIUM	HIGH
				Axle 1 = 26,480 lbs		135% of FBF			Axle 1 = 26,480 lbs		132% of FBF		
				Axle 2 = 26,950 lbs					Axle 2 = 26,950 lbs				

Category II: Self-Propelled IoH



IoH Category	Photo	Vehicle ID	Vehicle Make	EMPTY CONFIGURATION					FULLY-LOADED CONFIGURATION				
				Gross Weight	Meets FBF?	Controlling Element for FBF	BRIDGE Impact	PAVEMENT Impact	Gross Weight	Meets FBF?	Controlling Element for FBF	BRIDGE Impact	PAVEMENT Impact
II		N/A	John Deere Forage Harvester 7980	Total = 36,538 lbs	NO	Axle 1 = 21,923 lbs	LOW	MEDIUM	Total = 45,718 lbs	NO	Axle 2 = 27,431 lbs	MEDIUM	MEDIUM
				Axle 1 = 21,923 lbs		110% of FBF			Axle 1 = 27,431 lbs		137% of FBF		
				Axle 2 = 14,615 lbs					Axle 2 = 18,287 lbs				
II		S3	AGCO Terragator 8204	Total = 31,600 lbs	YES	Axle 2 = 17,860 lbs	LOW	LOW	Total = 49,000 lbs	NO	Axle 2 = 29,000 lbs	MEDIUM	HIGH
				Axle 1 = 13,920 lbs		89% of FBF			Axle 1 = 20,000 lbs		145% of FBF		
				Axle 2 = 17,680 lbs					Axle 2 = 29,000 lbs				
II		R4	AGCO Terragator 9203	Total = 37,540 lbs	NO	Axle 2 = 23,840 lbs	LOW	HIGH	Total = 58,000 lbs	NO	Axle 2 = 41,200 lbs	MEDIUM	HIGH
				Axle 1 = 13,700 lbs		119% of FBF			Axle 1 = 16,800 lbs		206% of FBF		
				Axle 2 = 23,840 lbs					Axle 2 = 41,200 lbs				
II		R5	AGCO Terragator 8144	Total = 31,730 lbs	YES	Axle 2 = 16,440 lbs	LOW	LOW	Total = 47,100 lbs	NO	Axle 2 = 30,700 lbs	MEDIUM	HIGH
				Axle 1 = 15,290 lbs		82% of FBF			Axle 1 = 16,400 lbs		153% of FBF		
				Axle 2 = 16,440 lbs					Axle 2 = 30,700 lbs				
II		R6	AGCO Terragator 3104	Total = 42,050 lbs	NO	Axle 1 = 24,150 lbs	LOW	HIGH	Total = 74,700 lbs	NO	Axle 2 = 48,700 lbs	HIGH	VERY HIGH
				Axle 1 = 24,150 lbs		121% of FBF			Axle 1 = 26,000 lbs		244% of FBF		
				Axle 2 = 17,900 lbs					Axle 2 = 48,700 lbs				

Implements of Husbandry Study

Category III: IoH CMV Conversions

IoH Category	Photo	Vehicle ID	Vehicle Make	EMPTY CONFIGURATION					FULLY-LOADED CONFIGURATION				
				Gross Weight	Meets FBF?	Controlling Element for FBF	BRIDGE Impact	PAVEMENT Impact	Gross Weight	Meets FBF?	Controlling Element for FBF	BRIDGE Impact	PAVEMENT Impact
III		S4	Homemade	Total = 27,860 lbs	YES	Total = 27,860 lbs	LOW	LOW	Total = 65,000 lbs	NO	Tandem = 49,000 lbs	MEDIUM	MEDIUM
				Axle 1 = 12,680 lbs		70% of FBF			Axle 1 = 16,000 lbs		144% of FBF		
				Axle 2 = 6,480 lbs					Axle 2 = 24,500 lbs				
				Axle 3 = 8,700 lbs					Axle 3 = 24,500 lbs				
III		S5	Homemade	Total = 28,100 lbs	YES	Total = 28,100 lbs	LOW	LOW	Total = 62,300 lbs	NO	Tandem = 43,000 lbs	MEDIUM	LOW
				Axle 1 = 12,700 lbs		70% of FBF			Axle 1 = 19,300 lbs		126% of FBF		
				Axle 2 = 8,320 lbs					Axle 2 = 21,500 lbs				
				Axle 3 = 7,080 lbs					Axle 3 = 21,500 lbs				

Category IV: IoH Vehicle Trains

IoH Category	Photo	Vehicle ID	Vehicle Make	EMPTY CONFIGURATION					FULLY-LOADED CONFIGURATION				
				Gross Weight	Meets FBF?	Controlling Element for FBF	BRIDGE Impact	PAVEMENT Impact	Gross Weight	Meets FBF?	Controlling Element for FBF	BRIDGE Impact	PAVEMENT Impact
IV		T1	John Deere 8430 w/Houle Tank	Total = 44,500 lbs	YES	Axle 2 = 17,300 lbs	LOW	LOW	Total = 81,000 lbs	NO	Axle 2 = 25,000 lbs	HIGH	MEDIUM
				Axle 1 = 12,940 lbs		87% of FBF			Axle 1 = 11,000 lbs		125% of FBF		
				Axle 2 = 17,300 lbs					Axle 2 = 25,000 lbs				
				Axle 3 = 6,280 lbs					Axle 3 = 21,000 lbs				
				Axle 4 = 7,980 lbs					Axle 4 = 24,000 lbs				
IV		T2	M. Ferguson 8470 w/Husky Tank	Total = 30,780 lbs	YES	Axle 2 = 12,700 lbs	LOW	LOW	Total = 63,900 lbs	NO	Tandem = 36,600 lbs	MEDIUM	LOW
				Axle 1 = 9,080 lbs		64% of FBF			Axle 1 = 9,500 lbs		108% of FBF		
				Axle 2 = 12,700 lbs					Axle 2 = 17,800 lbs				
				Axle 3 = 4,520 lbs					Axle 3 = 18,800 lbs				
				Axle 4 = 4,480 lbs					Axle 4 = 17,800 lbs				
IV		T6	John Deere 8230 w/Husky Tank	Total = 45,860 lbs	YES	Axle 2 = 17,600 lbs	LOW	LOW	Total = 89,700 lbs	NO	Tandem = 55,000 lbs	HIGH	HIGH
				Axle 1 = 13,220 lbs		88% of FBF			Axle 1 = 11,200 lbs		162% of FBF		
				Axle 2 = 17,600 lbs					Axle 2 = 23,500 lbs				
				Axle 3 = 7,140 lbs					Axle 3 = 23,500 lbs				
				Axle 4 = 7,900 lbs					Axle 4 = 31,500 lbs				
IV		T7	Case IH 275 w/Houle Tank	Total = 58,540 lbs	YES	Axle 2 = 19,020 lbs	LOW	MEDIUM	Total = 105,300 lbs	NO	Tridem = 71,000 lbs	HIGH	HIGH
				Axle 1 = 13,880 lbs		95% of FBF			Axle 1 = 10,300 lbs		169% of FBF		
				Axle 2 = 19,020 lbs					Axle 2 = 24,000 lbs				
				Axle 3 = 8,520 lbs					Axle 3 = 23,000 lbs				
				Axle 4 = 8,440 lbs					Axle 4 = 24,000 lbs				
IV		T8	Case IH 485 w/Houle Tank	Total = 78,290 lbs	NO	Axle 2 = 26,950 lbs	MEDIUM	HIGH	Total = 134,000 lbs	NO	Quad = 96,900 lbs	HIGH	HIGH
				Axle 1 = 26,480 lbs		132% of FBF			Axle 1 = 11,100 lbs		181% of FBF		
				Axle 2 = 26,950 lbs					Axle 2 = 26,000 lbs				
				Axle 3 = 6,120 lbs					Axle 3 = 22,500 lbs				
				Axle 4 = 6,140 lbs					Axle 4 = 24,800 lbs				
				Axle 5 = 6,080 lbs					Axle 5 = 24,800 lbs				
Axle 6 = 6,520 lbs	Axle 6 = 24,800 lbs												
IV		G1	Case IH 9330 w/Parker 938 Cart	Total = 37,900 lbs	YES	Axle 2 = 14,800 lbs	LOW	LOW	Total = 87,400 lbs	NO	Axle 3 = 49,000 lbs	HIGH	HIGH
				Axle 1 = 12,600 lbs		74% of FBF			Axle 1 = 8,700 lbs		245% of FBF		
				Axle 2 = 14,800 lbs					Axle 2 = 29,700 lbs				
				Axle 3 = 10,500 lbs					Axle 3 = 49,000 lbs				

Appendix G: Equipment Specifications

Vehicle axle weights are tabulated in this section for all tested load levels and test seasons. All weights were measured and presented in pounds as shown in Table G.1 through Table G.6. Consequently, the axle configurations and dimensions of tested vehicles are presented as shown in Figure G.1 through Figure G.3. All dimensions were measured and presented in inches. * MnROAD Study

Table G.1. Vehicle Axle Weights for Spring 2008 Test (MnROAD Study)

Vehicle Load Level	S4, Homemade, 4,400 gal				S5, Homemade, 4,400 gal				T1, John Deere 8430, 6,000 gal			
	0%	25%	50%	80%	0%	25%	50%	80%	0%	25%	50%	80%
Axle 1	10,440	11,600	12,560	13,540	12,700	14,180	15,700	17,520	12,940	12,360	11,440	11,080
Axle 2	7,700	11,000	15,060	19,320	8,320	12,120	15,740	19,760	17,300	19,220	23,000	24,560
Axle 3	6,820	11,200	15,540	20,240	7,080	10,860	15,150	19,900	6,280	11,540	16,760	21,000
Axle 4									7,980	13,440	19,550	24,680
Axle 5												
Axle 6												
Total	24,960	33,800	43,160	53,100	28,100	37,160	46,590	57,180	44,500	56,560	70,750	81,320
Vehicle Load Level	S3, Terragator 8204				T2, M.Ferguson 8470, 4,000 gal				T6, John Deere 8430, 6,000 gal			
	0%	25%	50%	80%	0%	25%	50%	80%	0%	25%	50%	80%
Axle 1	13,920	14,000	14,120	14,980	9,080	9,060	8,580	8,400	13,220	12,660	11,940	11,600
Axle 2	17,680	20,880	24,820	30,600	12,700	13,460	15,220	16,180	17,600	17,700	20,860	22,420
Axle 3					4,520	8,260	12,100	16,920	7,140	12,420	16,620	22,440
Axle 4					4,480	7,660	11,440	15,620	7,900	13,760	19,760	26,640
Axle 5												
Axle 6												
Total	31,600	34,880	38,940	45,580	30,780	38,440	47,340	57,120	45,860	56,540	69,180	83,100

Table G.2. Vehicle Axle Weights for Fall 2008 Test (MnROAD Study)

Vehicle Load Level	R4, Terragator 9203				T6, John Deere 8430, 6,000 gal				T7, Case IH 245, 7,300 gal			
	0%	25%	50%	80%	0%	25%	50%	80%	0%	25%	50%	80%
Axle 1	13,700	13,760	14,440	14,940	13,390	12,600	11,900	11,660	11,620	11,040	11,100	9,580
Axle 2	23,840	28,640	32,820	38,420	16,980	19,200	20,660	22,640	16,820	18,880	19,500	22,680
Axle 3					7,560	12,740	17,920	24,880	6,380	10,680	14,420	19,380
Axle 4					7,480	14,360	20,820	26,900	6,600	10,980	15,940	21,040
Axle 5									6,520	10,540	15,900	21,120
Axle 6												
Total	37,540	42,400	47,260	53,360	45,410	58,900	71,300	86,080	47,940	62,120	76,860	93,800
Vehicle Load Level	T8, Case IH 485, 9,500 gal				Mn80							
	0%	25%	50%	80%	80-kip							
Axle 1	26,480	25,620		25,200	12,000							
Axle 2	26,950	30,220		34,540	17,000							
Axle 3	6,120	9,670		18,240	17,000							
Axle 4	6,140	10,660		20,360	16,000							
Axle 5	6,080	10,380		20,220	18,000							
Axle 6	6,520	10,400		20,220								
Total	78,290	96,950		138,780	80,000							

Table G.3. Vehicle Axle Weights for Spring 2009 Test (MnROAD Study)

Vehicle	S4, Homemade, 4,400 gal				S5, Homemade, 4,400 gal				R4, Terragator 9203			
Load Level	0%	25%	50%	80%	0%	25%	50%	80%	0%	25%	50%	80%
Axle 1	12,680	13,940	15,100	16,600	11,140	12,080	13,280	15,400	12,800	13,020	13,620	13,900
Axle 2	6,480	9,900	15,600	19,520	6,940	11,120	14,320	19,400	23,720	28,160	34,440	39,340
Axle 3	8,700	12,420	16,280	21,460	7,100	10,840	15,340	20,040				
Axle 4												
Axle 5												
Axle 6												
Total	27,860	36,260	46,980	57,580	25,180	34,040	42,940	54,840	36,520	41,180	48,060	53,240
Vehicle	R5, Terragator 8144				T6, John Deere 8230, 6,000 gal				T7, Case IH 335, 7,300 gal			
Load Level	0%	25%	50%	80%	0%	25%	50%	80%	0%	25%	50%	80%
Axle 1	15,240	15,580	16,260	16,780	7,900	7,500	7,240	6,320	13,880	13,760	11,820	17,240
Axle 2	16,240	19,940	23,340	26,960	15,860	17,720	19,140	20,960	19,020	20,440	23,080	18,360
Axle 3					7,140	12,160	17,460	20,480	8,520	12,680	17,680	22,840
Axle 4					7,880	13,240	19,400	22,460	8,440	12,780	17,540	22,720
Axle 5									8,680	13,180	17,930	22,440
Axle 6												
Total	31,480	35,520	39,600	43,740	38,780	50,620	63,240	70,220	58,540	72,840	88,050	103,600
Vehicle	T8, Case IH 335, 9,500 gal				Mn80	Mn102						
Load Level	0%	25%	50%	80%	80-kip	102-kip						
Axle 1	17,400	17,800	17,240	15,540	11,640	12,880						
Axle 2	18,060	21,480	22,260	26,040	17,080	22,180						
Axle 3	5,660	9,700	14,540	18,760	16,760	21,540						
Axle 4	6,100	10,500	16,200	21,280	18,460	22,680						
Axle 5	5,720	10,240	16,060	20,840	15,620	22,960						
Axle 6	5,960	10,620	15,780	21,380								
Total	58,900	80,340	102,080	123,840	79,560	10,2240						

Table G.4. Vehicle Axle Weights for Fall 2009 Test (MnROAD Study)

Vehicle	R5, Terragator 8144			T6, John Deere 8230, 6,000 gal			T7, Case IH 275, 7,300 gal		
Load Level	0%	50%	100%	0%	50%	100%	0%	50%	100%
Axle 1	15,290	16,450	17,150	9,110	8,900	8,100	8,800	8,100	6,900
Axle 2	16,440	23,500	29,950	15,710	18,600	21,400	13,500	16,400	19,800
Axle 3				6,990	16,600	26,500	7,700	17,100	26,300
Axle 4				7,900	20,300	33,500	7,500	16,900	26,200
Axle 5							7,600	17,100	26,000
Axle 6									
Total	31,730	39,950	47,100	39,710	64,400	89,500	45,100	75,600	105,200
Vehicle	T8, Case IH 335, 9,500 gal			Mn80	Mn102				
Load Level	0%	50%	100%	80-kip	102-kip				
Axle 1	16,800	16,100	14,800	12,100	12,780				
Axle 2	18,000	21,000	25,200	17,440	24,440				
Axle 3	5,900	14,900	23,300	16,050	20,780				
Axle 4	5,900	15,100	23,700	18,830	24,330				
Axle 5	5,700	15,100	23,500	16,670	22,910				
Axle 6	5,900	15,400	23,700						
Total	58,200	97,600	134,200	81,090	105,240				

Table G.5. Vehicle Axle Weights for Spring 2010 Test (MnROAD Study)

Vehicle	R6, Terragator 3104			T6, John Deere 8230, 6,000 gal			Mn80	Mn102
	0%	50%	100%	0%	50%	100%	80-kip	102-kip
Axle 1	24,150	28,300	32,800	8,200	7,500	6,200	12,550	12,200
Axle 2	17,900	28,700	41,900	17,600	21,000	23,500	16,000	22,950
Axle 3				7,200	16,900	26,000	17,800	22,250
Axle 4				8,000	21,400	33,900	16,000	20,700
Axle 5							17,800	25,000
Axle 6								
Total	42,050	57,000	74,700	41,000	66,800	89,600	80,150	103,100

Table G.6. Vehicle Axle Weights for Fall 2010 Test (MnROAD Study)

Vehicle	G1, Case IH 9330, 1,000 bushels		T6, New Holland TG245, 6,000 gal		Mn80	Mn102
	0%	100%	0%	100%	80-kip	102-kip
Axle 1	12,600	11,500	11,400	11,200	11,450	12,400
Axle 2	14,800	18,700	17,500	23,000	17,200	22,950
Axle 3	10,500	57,200	7,000	24,700	17,200	22,250
Axle 4			7,900	31,400	14,300	19,900
Axle 5					19,300	25,600
Axle 6						
Total	37,900	87,400	43,800	90,300	79,450	103,100

Figure G.1. Dimensions for Vehicles S4, S5, and G1 (MnROAD Study)

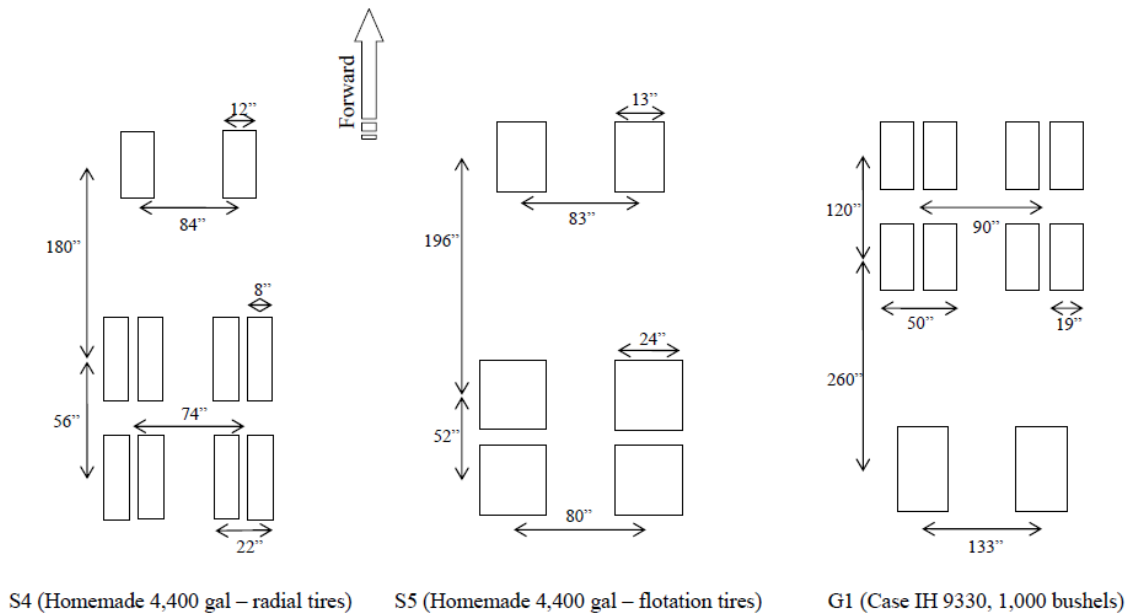

Figure G.2. Dimensions for Vehicles R4, R5, and R6 (MnROAD Study)

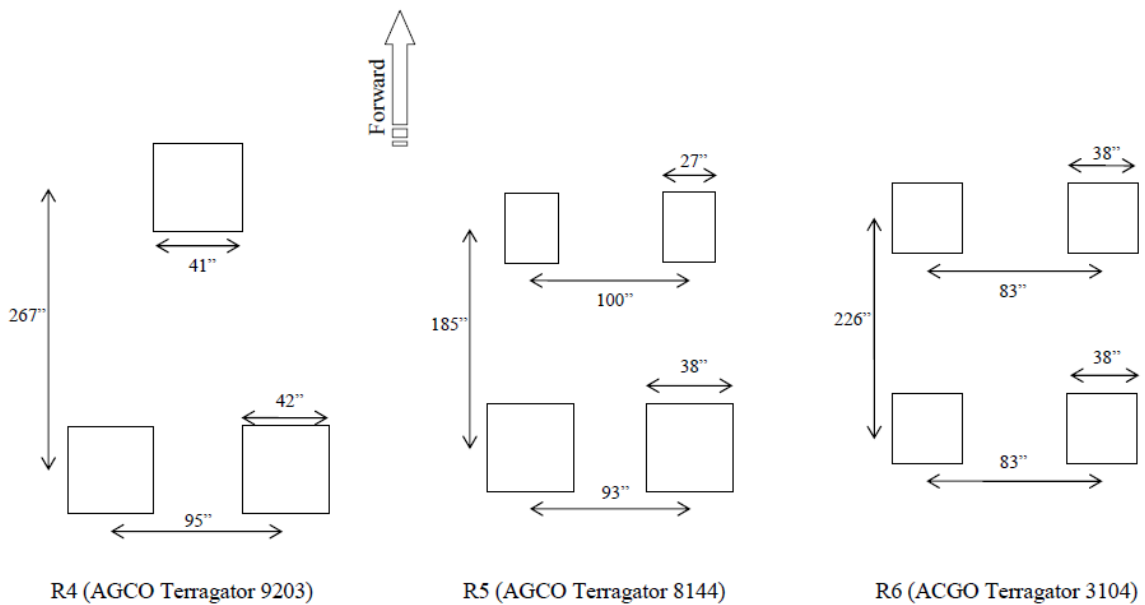

Figure G.3. Dimensions for Vehicles T6, T7, and T8 (MnROAD Study)

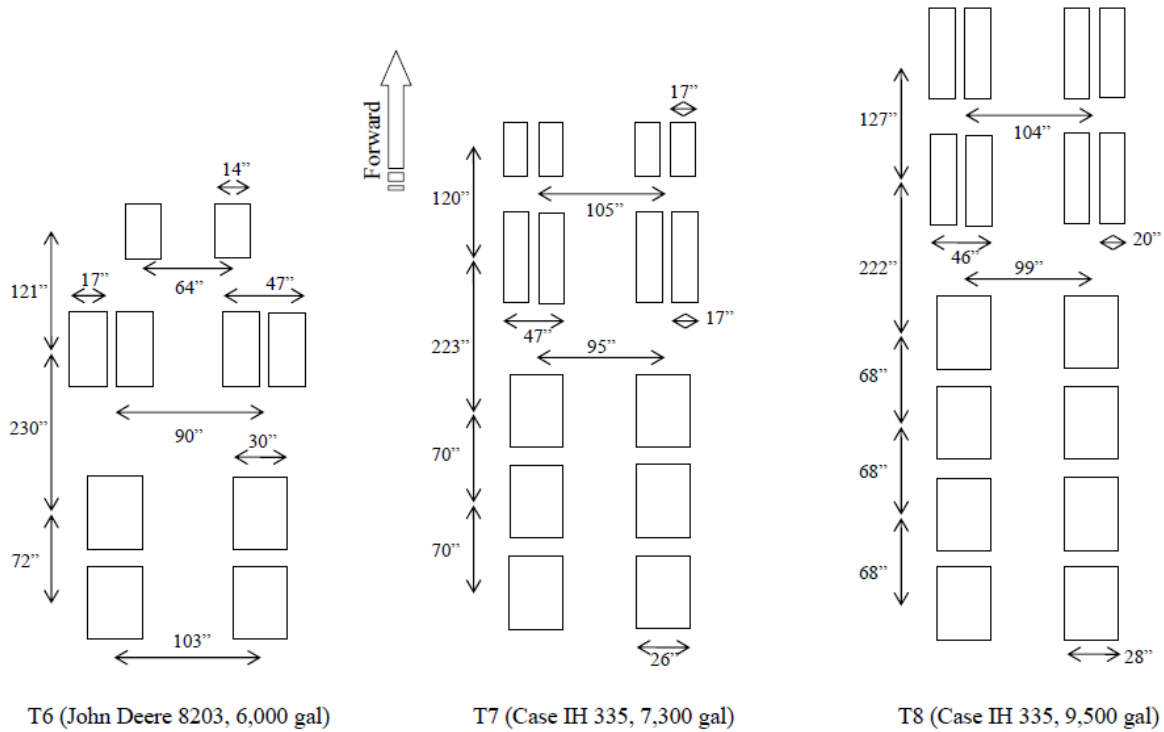

Figure G.4. Self-Propelled Forage Harvester Specifications (Estimates based-off published manufacturer data).

John Deere Model	Length(in)	Width(in)	Height(in)	Total Weight(lbs)	Drive Axle Weight(lbs)	Rear Axle Weight(lbs)
7980 without heads	267	136	147	36,538	21,923	14,615
7980 with 12 row corn head	361	136	147	45,718	27,431	18,287
7980 with largest hay head	314	190	147	40,645	23,907	15,938
Maximum Dimensions	361	190	147	45,718	27,431	18,287

Implements of Husbandry Study

Phase II Report to the Secretary of the Wisconsin Department of Transportation

Website: <http://www.dot.wisconsin.gov/business/index.htm>

Contact: IoHStudyFeedback@dot.wi.gov

Wisconsin Department of Transportation
Hill Farms State Transportation Building
4802 Sheboygan Ave.
P.O. Box 7910
Madison, Wisconsin 53707-7910

Implements of Husbandry Study

Phase II Report to the Secretary of the Wisconsin Department of Transportation

Website: <http://www.dot.wisconsin.gov/business/index.htm>

Contact: IoHStudyFeedback@dot.wi.gov